

User Guide

Danfoss Ally™ Pro

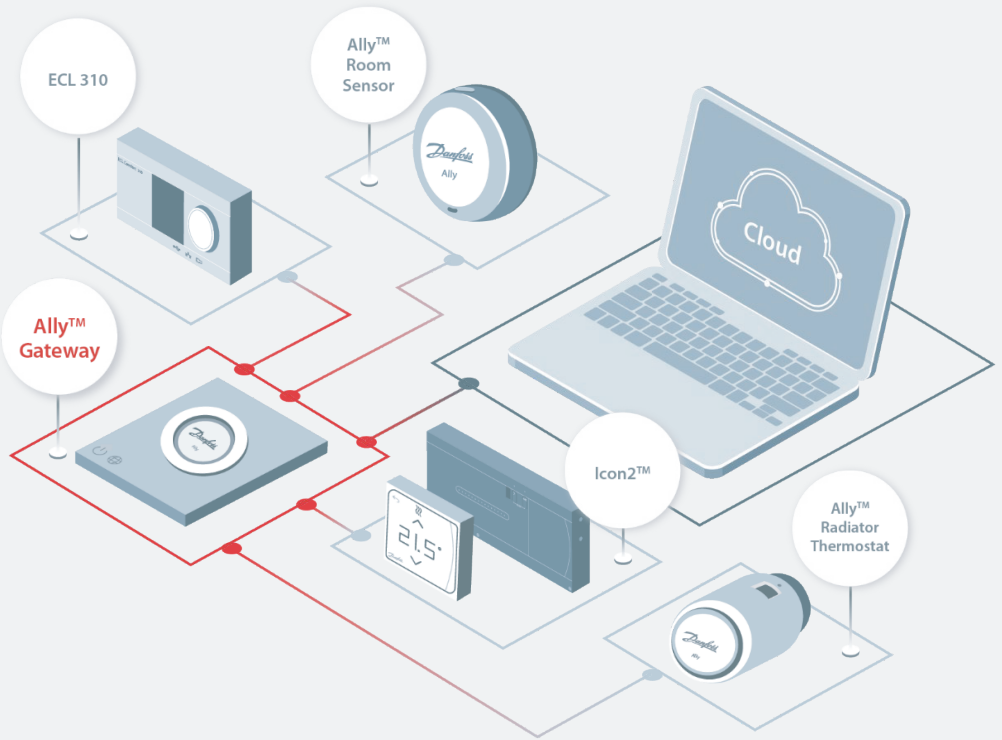

Manage your building smarter

1. Introduction to Danfoss Ally™ Pro	3
1.1. The Difference between core Danfoss Ally™ and Ally™ Pro	4
1.2. Key Values with Ally™ Pro	4
1.3. Danfoss Ally™ and Danfoss Ally™ Pro System Structure	5
1.4. Ally™ Pro Specifications	6
1.4.1. Ally™ Pro Hierarchy	7
2. How to use Danfoss Ally™ Pro	8
2.1. Getting started	8
2.1.1. How to sign up	8
2.1.2. How to log in	10
2.1.3. Don't remember your Password?	11
2.2. Locations in Ally™ Pro	13
2.2.1. How to set a Location	15
2.2.2. How to delete a Location	16
2.2.3. How to assign existing Users to a Location	17
2.2.3.1. Capabilities and Limitations as "Facility Manager"	18
2.2.3.2. Capabilities and Limitations of "Read-only User"	19
2.2.3.3. How to view the User List	20
2.2.4. How to add a new Account to a Location	21
2.2.5. How to import a Home	24
2.2.6. How to import a Device	26
2.2.7. How to update the Home Map	27
2.2.8. How to add a Zone	29
2.2.8.1. How to place Devices into the Zone	31
2.2.8.2. How to remove Devices from a Zone	33
2.2.8.3. How to change Zone Map	34
2.2.8.4. Add Vacation to the Zone	36
2.2.8.5. How to view Vacation Plan in the Calendar	37
2.2.8.6. How to delete a Vacation Plan	38
2.2.8.7. Temperature Setting in the Zone	39
2.2.8.8. How to change one specific Device Temperature in a Zone	40
2.2.8.9. How to set a Schedule to a Zone	42
2.2.8.10. How to duplicate a Schedule	45
2.2.8.11. How to delete a Schedule	46
2.3. Device Alarms in Ally™ Pro	47
2.3.1. Enabled/disabled Alarms for all Devices	47
2.3.2. Enabled/disabled Alarms per Device	48
2.3.3. Home Alarms List	50
2.4. ECL in Ally™ Pro	52
2.4.1. How to add ECL Device	52
2.4.2. How to create an ECL Home without an Ally™ Account	53
2.4.3. ECL Devices	56
2.4.4. How to link Devices with ECL	59

1. Introduction to Danfoss Ally™ Pro

Danfoss Ally™ Pro enables the user to connect and control our range of Danfoss products in a browser version, for a better overview of the installation.

Danfoss Ally™ Pro is a perfect fit for light commercial buildings, public buildings, hotels and resorts, in which you typically have a larger quantity of heating devices. **Ally™ Pro** grants the facility manager full and precise heating control, from one central place. It allows for more **Ally™** systems across buildings, in one platform.

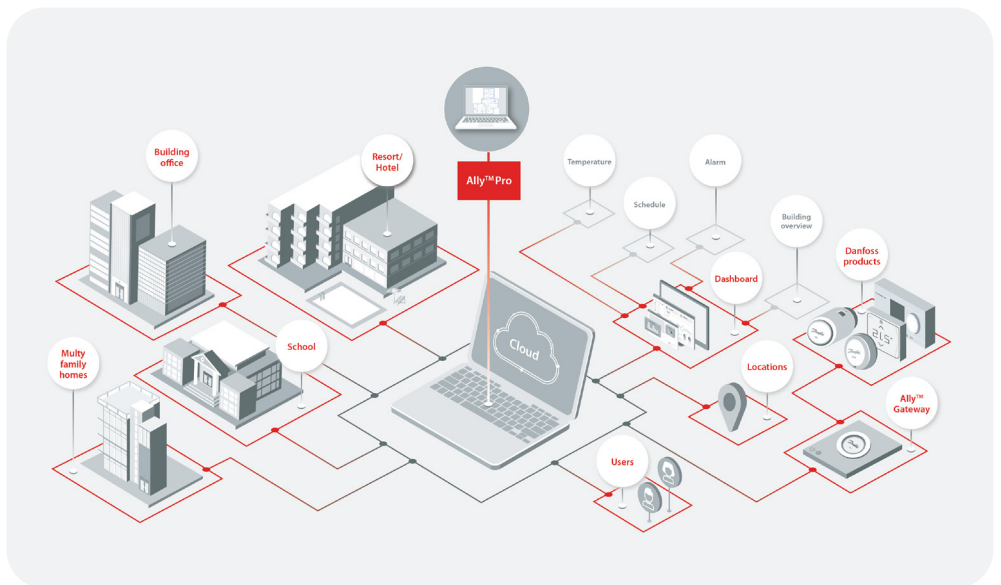

1.1. The Difference between core Danfoss Ally™ and Ally™ Pro

The core Danfoss Ally™ solution was developed for use in single family homes. The Danfoss Ally™ App suits the use in single family homes with a limited number of devices. These can be controlled easily, and with a good overview, in the Danfoss Ally™ App.

When buildings become larger and more complex, and the number of devices increases, it makes sense to control the installation via Danfoss Ally™ Pro. The overview of devices is easier from a browser. For more values with Ally™ Pro, please see ch. 1.2.

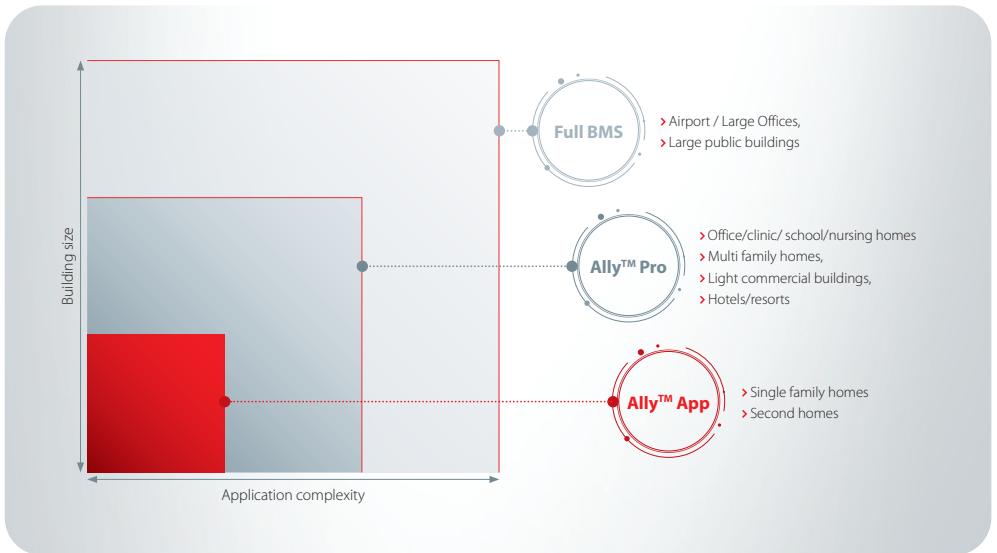

1.2. Key Values with Ally™ Pro:

- Web browser control functionality for free
- Connecting best-in-class products in one platform
- Excellent user interface
- Overview of all installations in one place
- Easy troubleshooting
- Energy savings
- Comfort control on user level
- No costly commitment to BMS suppliers
- No subscription or service fees

1.3. Danfoss Ally™ and Danfoss Ally™ Pro System Structure

- **Danfoss Ally™ App**

From the Danfoss Ally™ App you can control, schedule, and monitor your heating from anywhere and at any time. The app guides you through the quick setup and gives you complete overview and control. Danfoss Ally™ App is compatible with iOS and Android, and is best suited for use in single family homes.

- **Danfoss Icon™ Hydronic Floor Heating Control**

When combining the Icon™ system with the Ally™ Smart Heating Solution you obtain the Ally™ features on top. Ally™ together with Icon™ provide full Danfoss Icon™ functionality including the app control and automatic balancing.

Adding an expansion module to the Danfoss Icon™ system gives additional functionality and applications, e.g., demand-based supply temperature control or different floor cooling applications.

- **Danfoss Ally™ Pro System Structure**

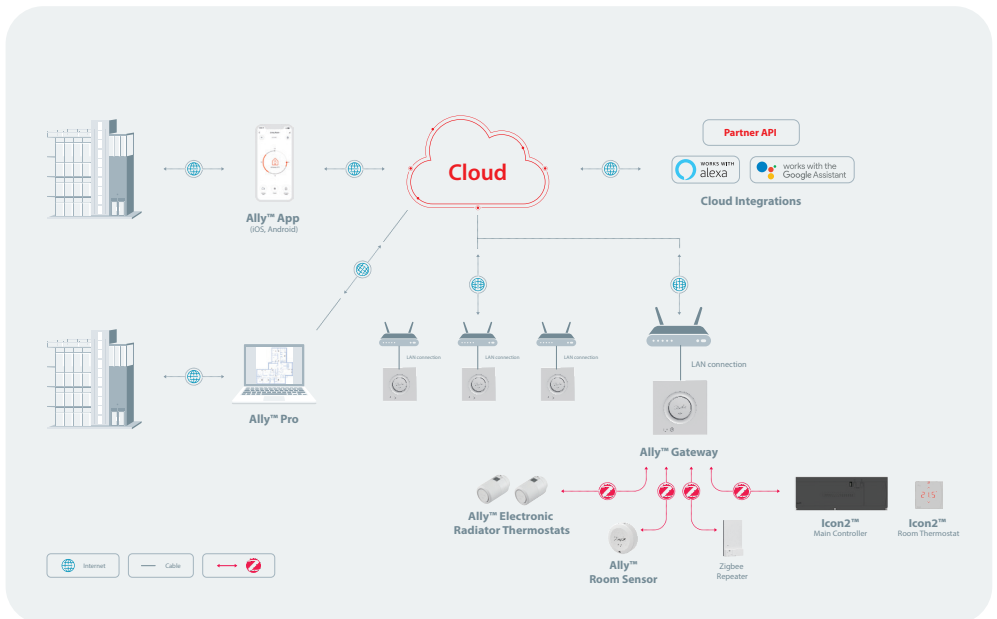

1.4. Ally™ Pro Specifications

Function	Ally™ Pro
Location	Max 10 Pcs
Home	Max 100 Pcs
Zone	Max 100 Pcs
Devices	Unlimited
Full access users (Facility Manager)	Max 10 users pr. Location
Read Only users	Max 10 users pr. Location
Files upload in Building Map	JPG and PNG only. Not PDF files
Browsers	Google Chrome, Microsoft Edge, Safari
Language	EN, DE, DK

1. What is “Account”?

This is your Ally™ user account. You can locate the email in the Danfoss Ally™ App.

2. What is “Location”?

These are the buildings in which you have the Danfoss Ally™ system installed. You can create as many locations as you want in the Ally™ Pro platform.

3. What is “Zone”?

This is a “place” in your location, that you can set up and manage. A “zone” should be created if a specific place or area has users (or rooms) which share the same features, e.g. all users in this area arrive in or leave the building at the same time. For example it could be a floor in a hotel, or a wing in a big school. You can manage each “zone” separately.

4. What is “Home”?

The homes that you have in the “Home” box are transferred from your Ally™ App.

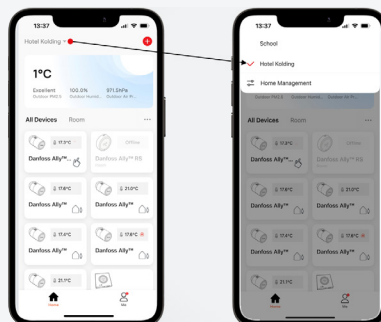

1.4.1. Ally™ Pro Hierarchy

The Ally™ Pro platform has a quite logical hierarchy structure. As an example, it is provided a simple schematic illustration below.

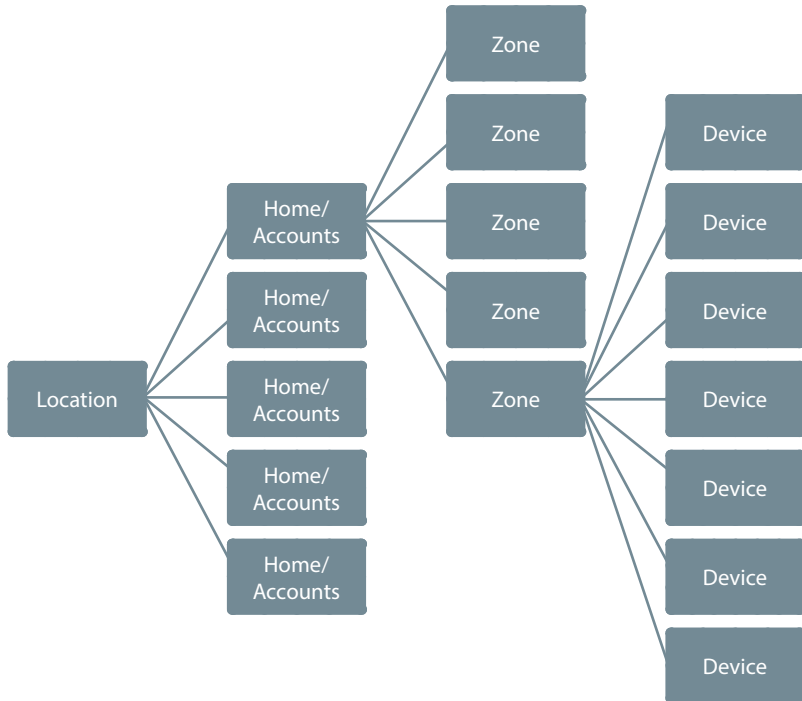

2. How to use Danfoss Ally™ Pro

2.1. Getting started

For the best possible set-up of an Ally™ Pro solution, proper and thorough planning is absolutely crucial. Before you get started, please make sure to refer to our “How to install” recommendations on allypro.danfoss.com . The time spent on overall consideration of needs, thorough and well-considered naming of devices, set-up of zones, and long-term planning, is well invested.

2.1.1. How to sign up

First, every user must register on the [Ally™ Pro](#) to be able to log in to the application.

1. Go to the website: [Ally™ Pro](#) .

2. Screen “Login with your mail” – To be able to register as a new user, first click on the “Login with Your mail” button.

Login with Your mail form contains:

1. Login with your mail (redirect link to Sign In/Sign Up page).

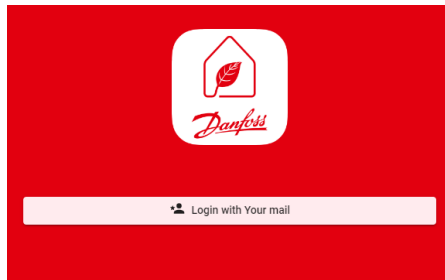

3. Screen “Log In” – To register as a new user click on the “Sign Up” tab, and the user will be redirected to the Sign-Up screen.

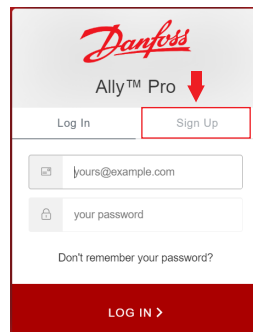

4. Screen “Sign Up” – To sign up, simply enter the “Email” and “Password” in the fields and click on the “Login” button.

Sign Up form contains

1. Email (input field);
2. Password (input field);
3. Your first name (input field)
4. Your last name (input field)
5. Sign Up (button)

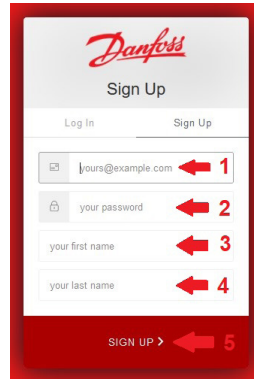

5. Screen with confirmation message – After successful registration, you will receive a confirmation link on your email account. Go to the email and open the email “Verify your mail” click on “Confirm my account”, and you will be redirected to the “Log In” page in the [Ally™ Pro](#) application.

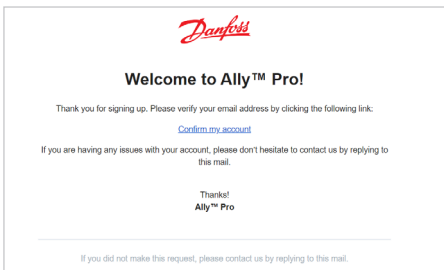
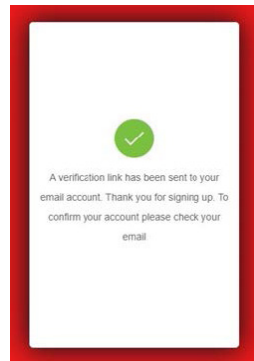

6. The screen “Log In” will be displayed – to log in, simply enter the “Email” and “Password” in the fields and click on the “Login” button.

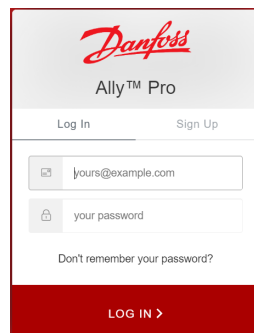

7. Screen “Administration Dashboard” – After successful login, the user will be redirected to the screen “Administration Dashboard”.

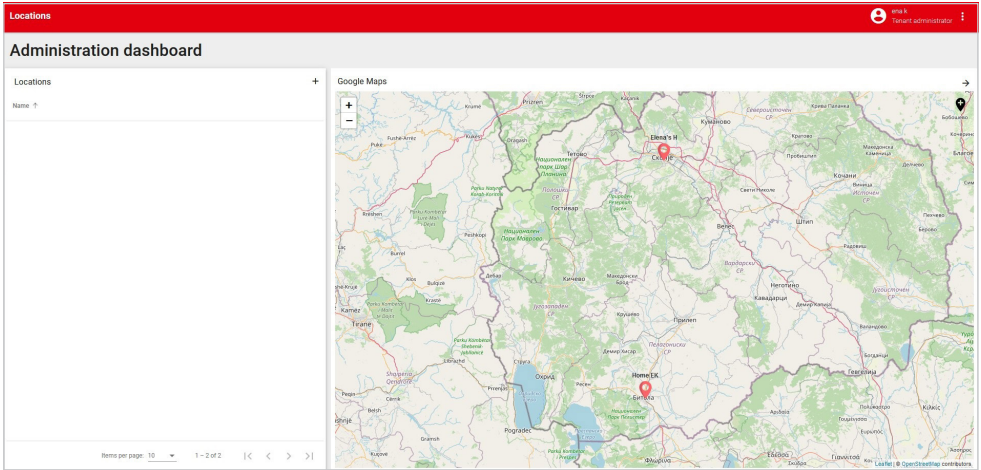

2.1.2. How to log in

Every user must log in to the [Ally™ Pro](#) to be able to use the functions.

1. Go to the website: [Ally™ Pro](#)

2. Screen “Login with your mail” – To be able to log In, first click on the “Login with Your mail” button.

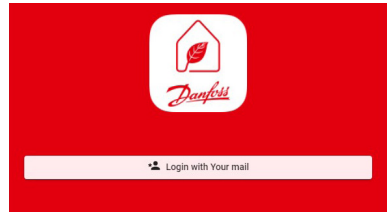

3. Screen “Log In” – To log in, simply enter the “Email” and “Password” in the fields and click on the “Login” button.

Login form contains:

1. Email (input field);
2. Password (input field);
3. Don't remember your password (redirect link to “Reset your password”)
4. Login (button)

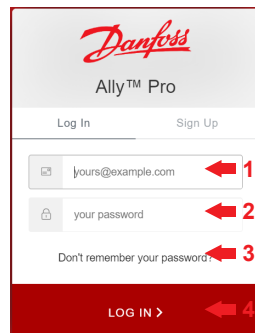

4. Screen “Administration Dashboard” – After successful login, the user will be redirected to the screen “Administration Dashboard”.

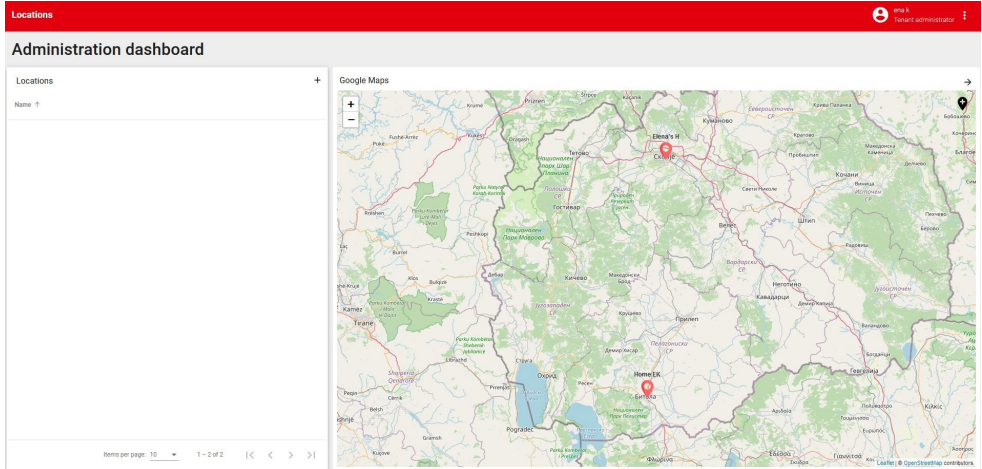

2.1.3. Don't remember your Password?

Each user must have been registered to [Ally™ Pro](#) to be able to reset and set a new password, if necessary.

1. Go to the website: [Ally™ Pro](#).
2. Screen “Login with your mail” – Click on the “Login with Your mail” button, and you will be redirected to the log-in display.

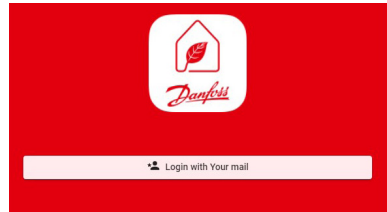

3. Screen “Log In” – If you don't remember your password you need to click on the “Don't remember your password?” button.

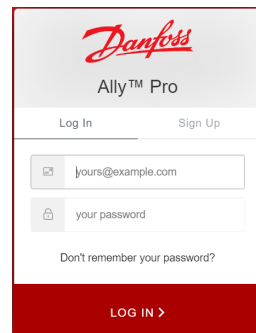

4. Screen “Reset your password” – After clicking on the “Don’t remember your password?” button you will be redirected to the “Reset your password” page. You need to enter your email address and click on the “Send Email” button. When you open your mail, you can see the link “Confirm”. When you click on the link you will be redirected to the “Change your password” page.

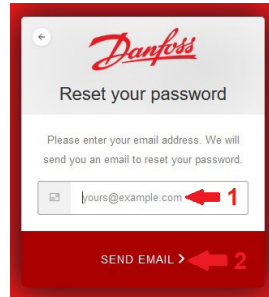

Reset your password form contains:

- 1. Email (input field);
- 2. Send Email (button).

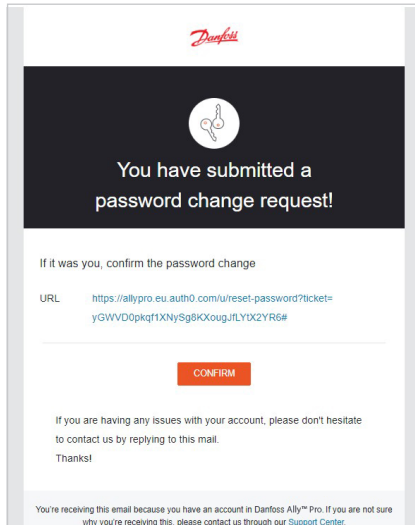

5. Screen “Change your password” – After clicking on “Confirm”, you will be redirected to the page “Change your password”. You need to enter your new password in the fields “New password” and “Re-enter new password” and click on the “Reset Password” button.

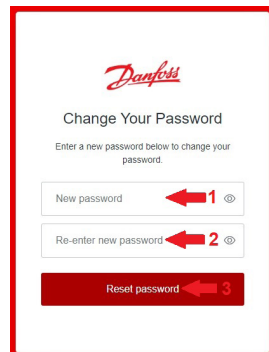

Change your password form contains:

- 1. New password (input field);
- 2. Re-enter the new password (input field);
- 3. Reset password (button).

6. Screen “Password Changed!” – After clicking on the “Reset password” button, you will be redirected to the screen “Password Changed”. Here, you can see the message for the successfully changed password. Then, click on the “Back to Ally™ Pro” button.

Change your password form contains:

1. Confirmation message (text);
2. Back to Ally™ Pro (button).

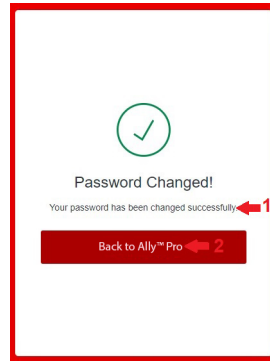

7. Screen “Login with your mail” – After clicking on the “Back to Ally™ Pro” button you will be redirected to the screen “Login with your mail”. You will then need to repeat the “How to Log in” steps.

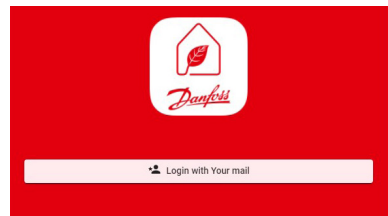

2.2. Locations in Ally™ Pro

As a user, you must be logged in to be able to create a location.

1. Screen “Administration Dashboard” – After successful login, you will see the administration dashboard with all options available.

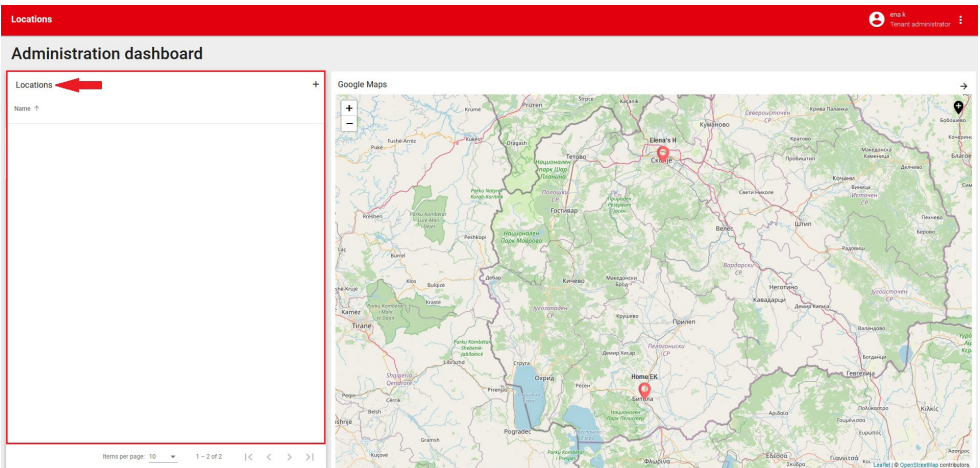

2. Screen “Location” will be displayed on the left side of the dashboard – When you are in the dashboard, you will be able to create a location.

Click on the “+” (plus) icon to create a location

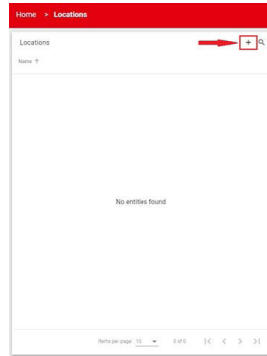

3. Pop-up window “Add Location” – After clicking on the “+” icon, the pop-up window with “Add Location” will be displayed. To create a location, simply enter the “Location Name” in the field and click on the “Create” button.

Add Location form contains:

1. Location Name (input field);
2. Create (button);
3. Cancel (button).

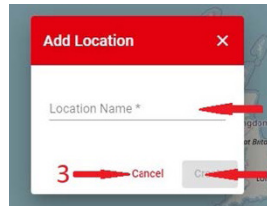

4. Pop-up window “Confirmation” – After clicking on the “Create” button, the pop-up window with the confirmation message “Location successfully created!” will be displayed.

Confirmation form contains:

1. Confirmation message (text);
2. Ok (button).

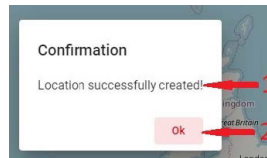

5. The created location will be displayed on the location dashboard – After clicking on the “Ok” button, the created location will be displayed with the setup menu for that location.

Created Location form contains:

1. Location name (text);
2. Set Location (button);
3. Delete Location (button);
4. Assign existing user to Location (button);
5. Users (button).

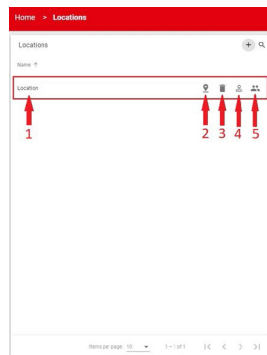

2.2.1. How to set a Location

Note that you need to first have created a location, in order to be able to set a location.

1. Screen “Locations” will be displayed on the dashboard – After successfully creating a location, you can set the coordinates of the location when you click on the **“Set Location”** icon.

2. Pop-up window “Location” – After clicking on the **“Set Location”**, the pop-up window with fields for coordinates will be displayed so you can set the current location.

You have two options to set coordinates on the fields latitude and longitude:

Option 1: Manually insert coordinates and click the checkmark icon to save the coordinates.

Option 2: Automatically obtain coordinates by clicking **“Get current location”** button, then click on the checkmark icon to save the coordinates. Then click on the **“Close”** button.

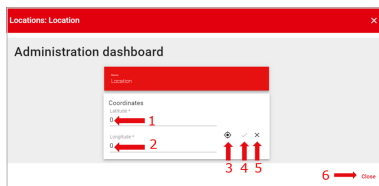
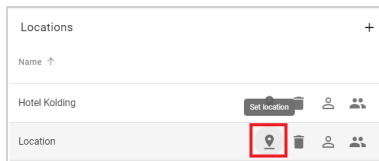

Get Current Location form contains:

1. Latitude (input field);
2. Longitude (input field);
3. Checkmark icon (button);
4. Cancel icon (button);
5. Get the current location (button);
6. Close (button).

3. Screen “Location” – After clicking on the **“Close”** button, you will be back on the **“Locations”** dashboard where you can see your location on the map.

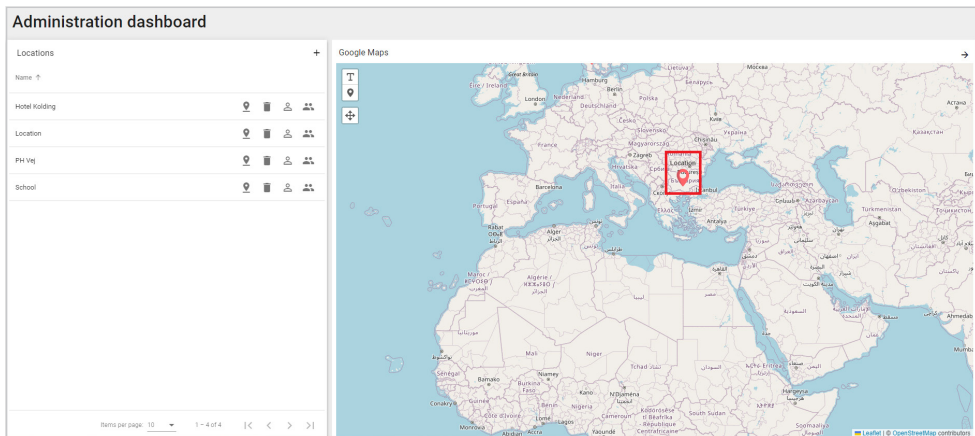

4. Screen “Location” – You can move the pin on the map by clicking “Drag-drop mode”  icon. After having placed pin in correct place, click “Finish”.

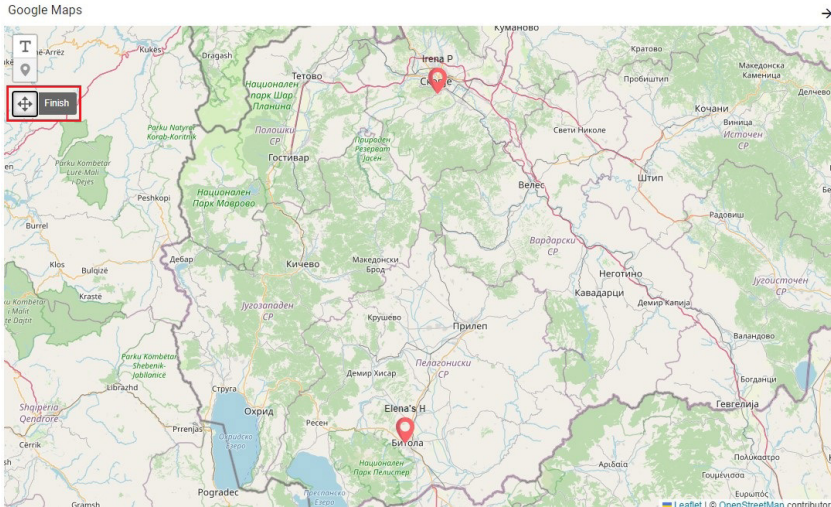

- Note:**
- If you do not set the location (or coordinates) when you create a location, or if you do not set it after importing a home, you will not be able to see the outdoor temperature of the imported home.
 - Note that in most cases, updates of the outdoor temperature will be reflected after 1 hour.

2.2.2. How to delete a Location

1. Screen “Locations” – You are able to delete an already created location by clicking on the “Delete Location”  icon.

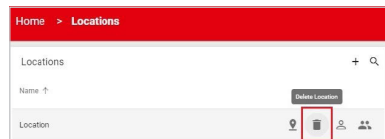

2. Pop-up window “Delete Account” – After clicking on the “Delete Location”, the pop-up window with the confirmation message “Are you sure you want to delete the location ‘Location?’” will be displayed. Click on the “Delete” button.

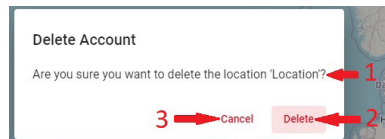

“Delete Account” form contains:

1. Confirmation message (text);
2. Delete (button);
3. Cancel (button).

3. Screen “Locations” – After clicking on the “Delete” button, you can see that the deleted location is no longer visible in the “Locations” display.

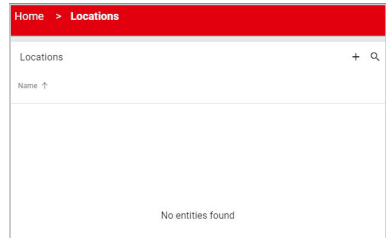

2.2.3. How to assign existing Users to a Location

First, you need a created location, in order to be able to assign existing users to the location. Note that the user must have an account in [Ally™ Pro](#), for you to be able to assign him or her to your location.



1. Screen “Locations” – After successfully creating a location, you will be able to assign users to your location when you click on the “Assign existing user to Location” icon.

2. Pop-up window “Assign User to ‘name of your location’” – After clicking on the “Assign existing user to Location”, the pop-up window with fields for the “Email” and “Select role” will be displayed. In the email field, insert the email address of the user you want to assign to the location. Then, select the drop-down menu with roles, and choose the role you want to assign to that user. Click on the “Assign” button.

Facility Manager: This role will give the user permission to make changes in this location.

Read-only User: It will give the user permission to only see the location.

Assign User to ‘name of your location’ form contains:

1. Email (input field);
2. Select role (select (dropdown) field);
3. Assign (button);
4. Cancel (button).

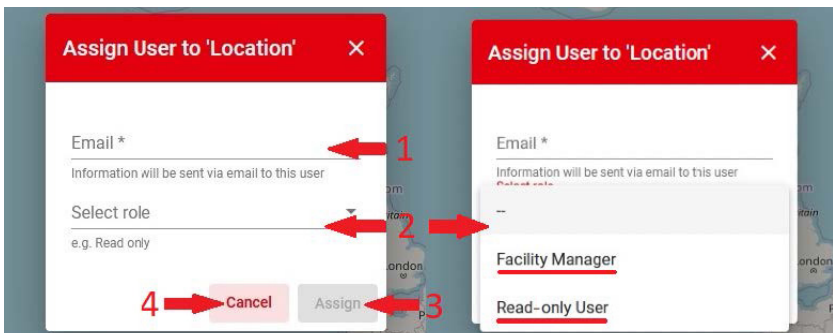

3. A pop-up window with confirmation – After clicking on the “Assign” button, a pop-up window with a confirmation message will appear to inform you that the user was successfully assigned to the location. Click “ok”.

Confirmation form contains:

1. Confirmation message (text);
2. Ok (button).

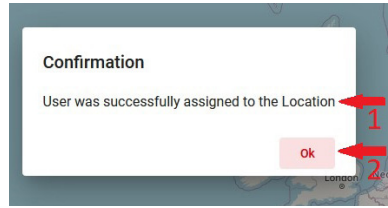

4. Screen “Locations” – After clicking on the Ok button, you can see the “Locations” display.

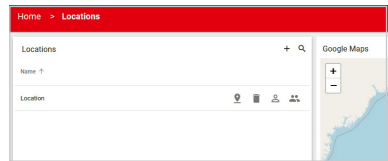

2.2.3.1. Capabilities and Limitations as “Facility Manager”

1. With a click on the “Assign existing user to Location”, the pop-up window with fields for the “Email” and “Select role” will be displayed. In the email field, you should input the user you want to assign to the location, and when you click on the select field, the dropdown menu with roles (Facility manager and Read-only User) will be displayed. Select the “Facility Manager” and click on the “Assign” button. The option “Facility Manager” will give the user permission to make changes to this location.

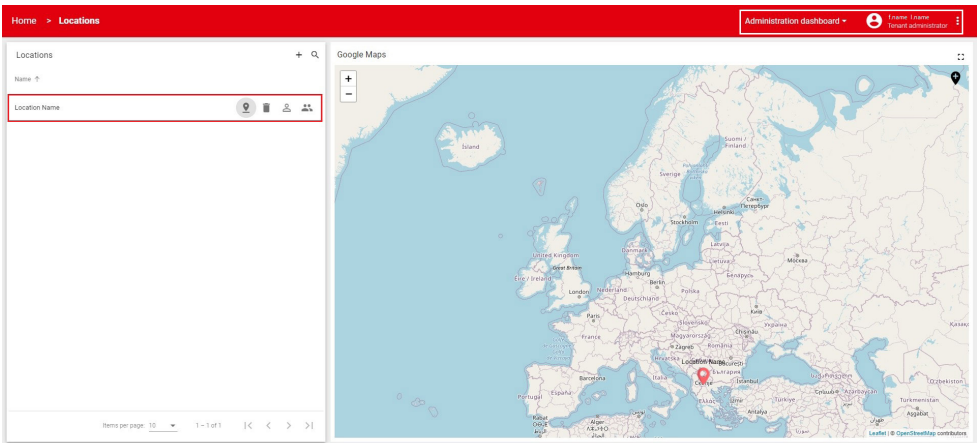

2.2.3.2. Capabilities and Limitations of “Read-only User”

1. Option “Read-only User” will give the user permission to view the location only. First, the user can see the “Administration dashboard” default display. By clicking on the arrow in the top right corner of the map (image 1) user can switch on the “Read-only” dashboard and can see the location in the “Locations” column (image 2).

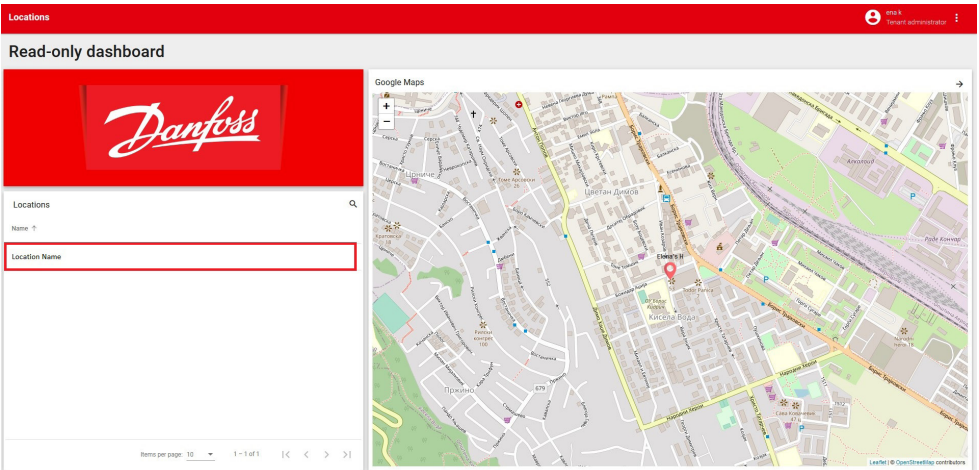
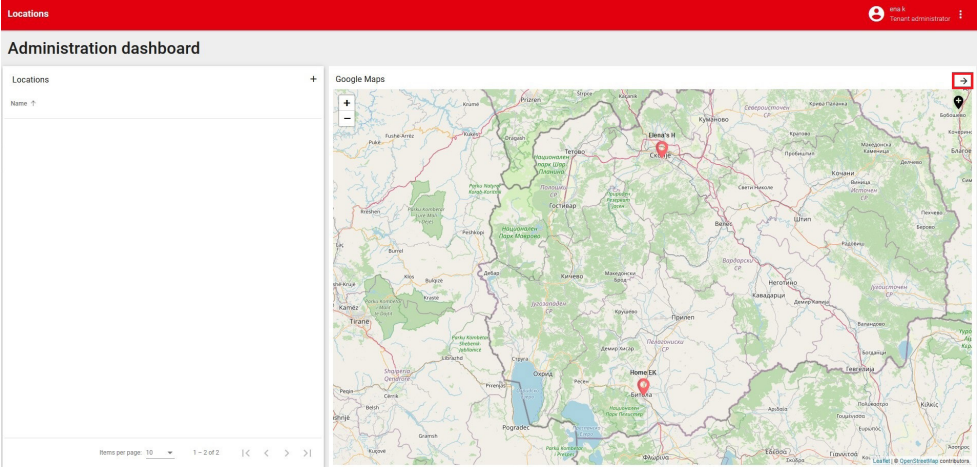

2.2.3.3. How to view the User List

An already created location is needed, in order to be able to enter into the user list.

1. Screen "Locations" – After successfully creating a location you will be able to enter into the "Users" list by clicking on the "Users" icon.



2. Screen "Users" – After clicking on the "Users" button you will be redirected to the "Users" screen where you can see the "Facility manager" and "Read-only Users" columns. When you create a location, your account will be automatically added to the "Facility manager" column.

Users form contains:

1. Facility Managers (column);
2. Read-only Users (column).

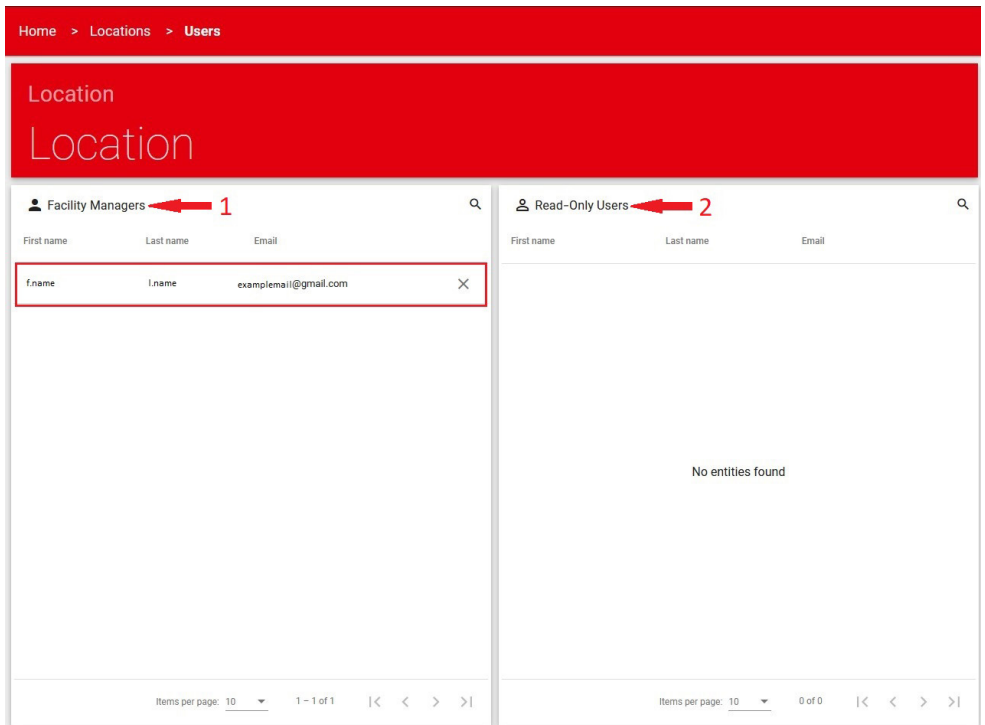

Note: When you assign users as "Facility Managers" or "Read-only Users" for your location, these will be displayed in the "Users" list with the roles you assign to them.

2.2.4. How to add a new Account to a Location

An already created location is needed, in order to be able to add an account to the location.

1. Screen “Location (name of location)” – After clicking on the created location, you will be redirected to the “Location” screen.

The Location screen contains:

- 1. Home (box with homes);
 - Manage home  icon;
 - Search  icon;
 - Expand to fullscreen  icon.
- 2. Accounts (box with accounts).
 - Add new account  icon;
 - Search  icon.

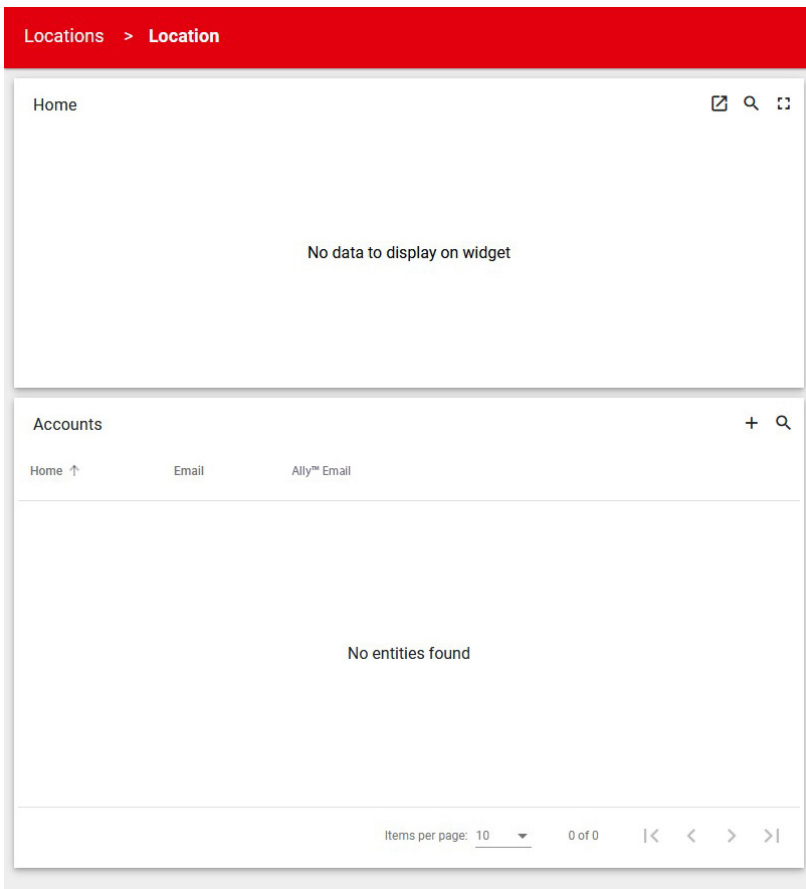

2. Screen “Location (name of location)” – Visible on the screen are the “Home” and “Accounts” boxes. The “Home” box contains the buildings which you can manage, while the “Accounts” box shows the users who have access to them. In the “Accounts”, click on the “+” icon to add an account.

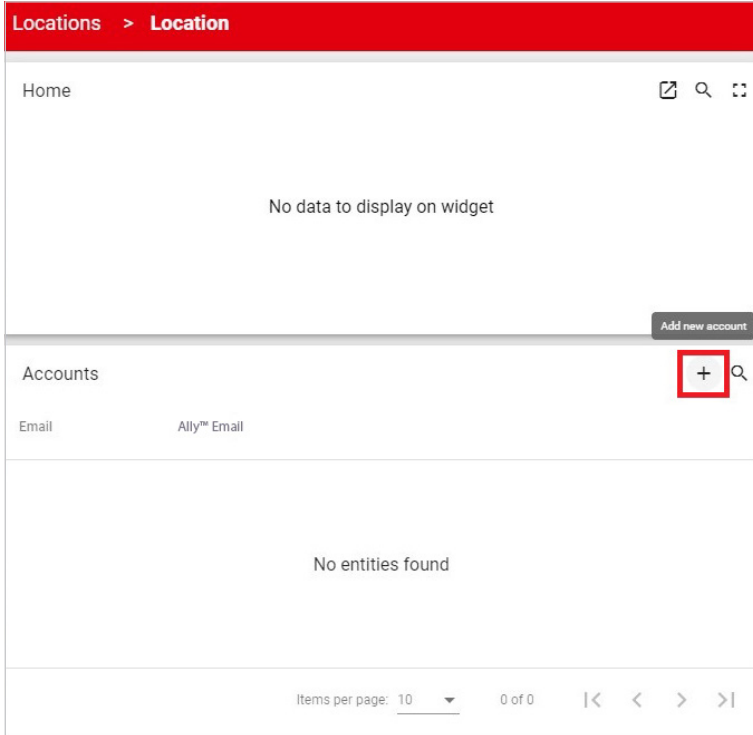

3. Pop-up window “Add new account” – After clicking on the “Add new account”+ icon, you will be able to see fields with “Ally™ Email” and “Location Name” (the location name is always shown as default in this field). Enter the value in the “Ally™ Email” and click on the “Create” button.

Add Location form contains:

1. Ally™ Email (input field);
2. Location Name (default field);
3. Create (button);
4. Cancel (button).

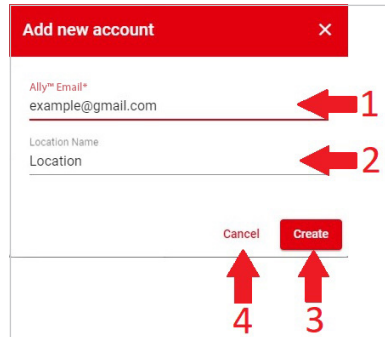

4. Screen “Location (name of location)” – After clicking on the “Create” button, you will be able to see in the account box the value you entered in the “Ally™ Email”. If you want to change the email account, you can do this by clicking the “Edit Ally™ Account” icon.

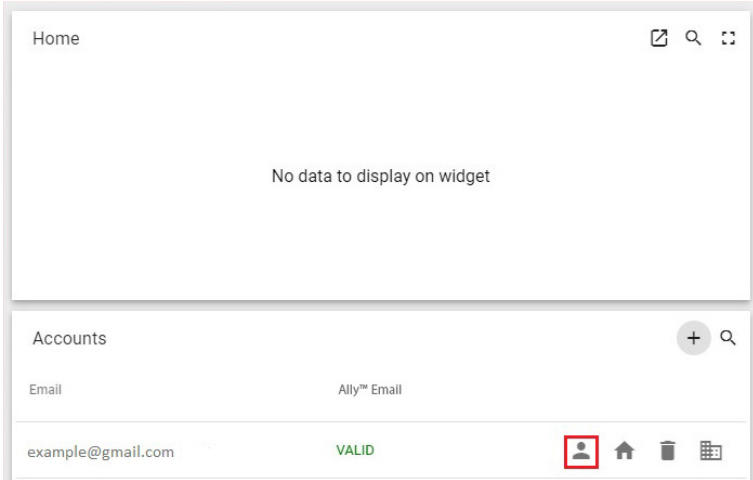

5. Pop-up window “Edit (email) Ally™ Account” – After clicking on the “Edit Ally™ Account” icon you can see the pop-up window with the field “Ally™ Email”. Enter the new email in the “Ally™ Email” field and click on the “Save” button.

Edit Ally™ Account form contains:

1. Ally™ Email (input field);
2. Save (button);
3. Cancel (button).

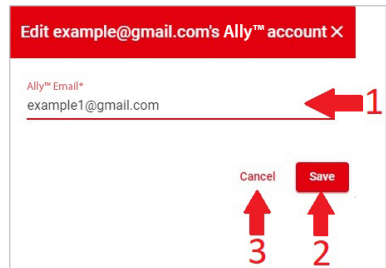

6. Screen “Location (name of location)” – After clicking on the “Save” button, in the account box, you will see the entered email. If this Ally™ email address is valid, an account is created.

Note that if the entered Ally™ email address is not valid, the account will not be created.

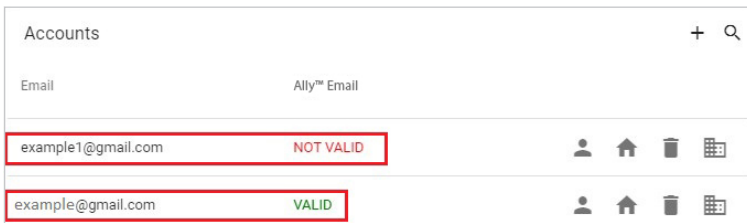

2.2.5. How to import a Home

An already created location is needed, as well as an account which has been added to the location, in order to be able to import homes.

1. Screen “Location (name of your created location)” – After successfully adding the account to the location, you will receive an email that it is linked to the account in [Ally™ Pro](#). Then, click on the “Import Homes” icon in order to import a home.

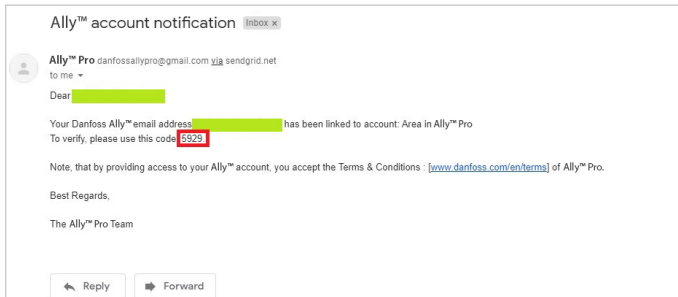
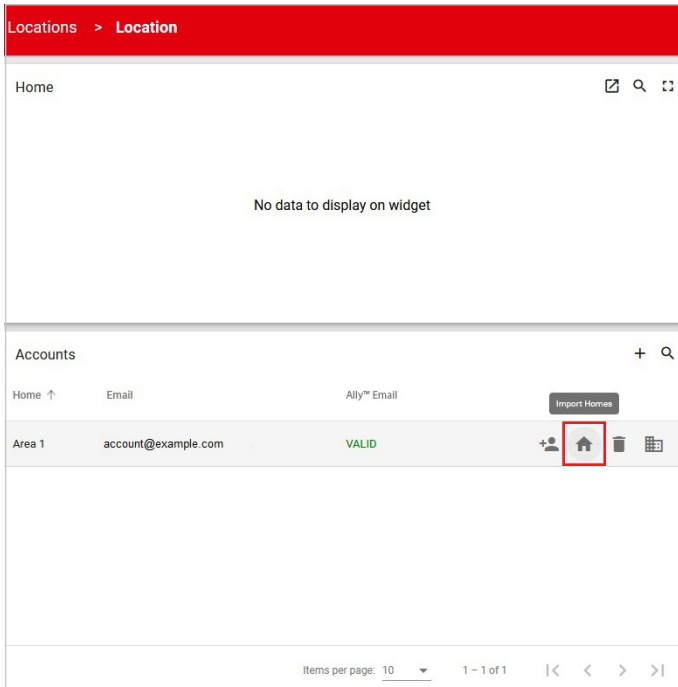

2. Pop-up window “Homes” – After clicking on the “Import Homes” icon, you can see the pop-up window with the “Enter your access code” field. The code is in the email you received when the email was added to the account.

Note: if you didn’t receive the access code, click on the “Resend Code” button.

Homes form contains:

1. Enter your access code (input field);
2. Confirm (button);
3. Cancel (button);
4. Resend code (button).

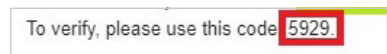
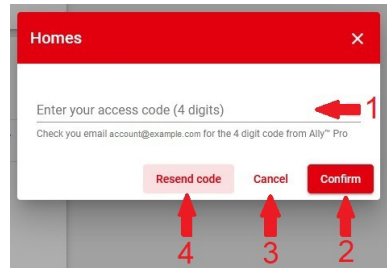

3. Screen “Homes” – After entering the access code in the “Enter your access code” field in the pop-up window in “Homes”, click on the “Confirm” button. You will again see the pop-up window “Homes”, but now with the option of selecting a home from the list. Then, click on the “Import” button to import a home to your location.

Homes’ second form contains:

1. List of home/s (check – option);
2. Import (button);
3. Cancel (button).

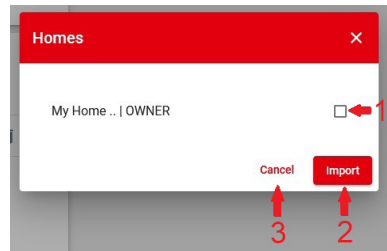

4. Screen “Location” – After clicking on the “Import” button in the “Home” box, you can see the imported home. Then, click on the imported home and you will be redirected to that “Home and zones” page.

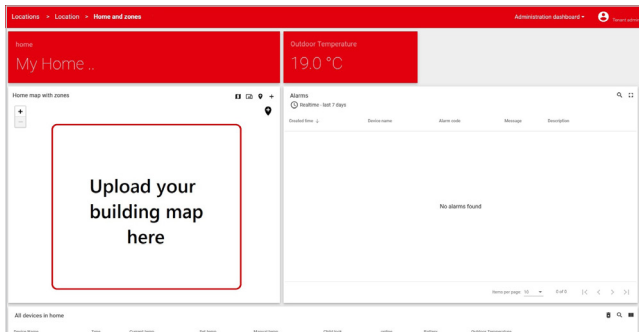

2.2.6. How to import a Device

An already imported home is needed, in order to import devices into the [Ally™ Pro](#).

1. Screen “Home and zones” – After the home is imported, you will be able to import devices. Click on **“Import Devices from Home”** to import devices.

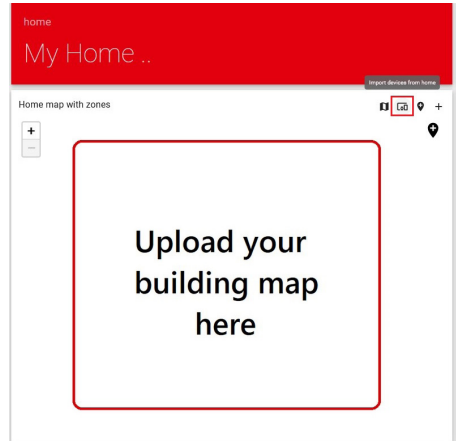

2. Pop-up window “Devices found in my Home” – After clicking on the **“Import devices from home”** icon in the pop-up window **“Devices found in my home”** icon, you can see all the devices you can import. They are all selected by default. Then, click **“Import”** button.

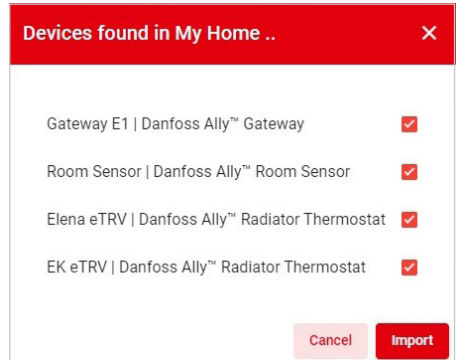

Note: If some devices should not be imported, you can uncheck these before clicking on the **“Import”** button.

3. Screen “Home and zones” – After clicking on the **“Import”** button, you will be able to see all imported devices in the **“All Devices in Home”** list.

Device Name	Type	Current temp	Set temp	Manual temp	Child lock	online	Battery	Outdoor Temperature
EK eTRV	Danfoss Ally™ Radiator Thermostat	24.4 °C	23 °C		enabled	online	68 %	
Elena eTRV	Danfoss Ally™ Radiator Thermostat	23.9 °C	21 °C	16 °C	disabled	online	62 %	
Room Sensor	Danfoss Ally™ Room Sensor	23.5 °C				online	100 %	
Gateway E1	Danfoss Ally™ Gateway					online		

2.2.7. How to update the Home Map

1. Screen “Home and zones” – After you import the devices, click on the “Update the Home Map” icon.

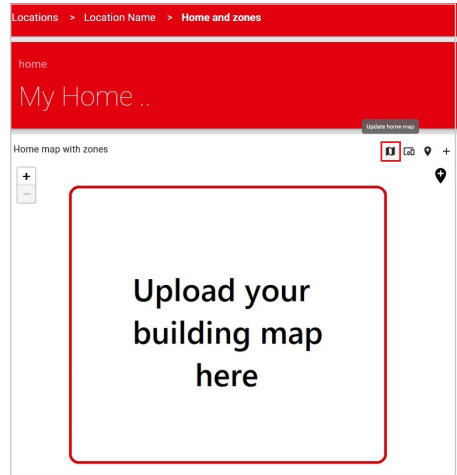

2. Pop-up window “Home map” – After clicking on the “Update the home map” in the pop-up window you can see instructions on how to upload the map. Click inside the map window, and file upload will open. Pick the relevant map or image, drag and drop. Click the checkmark and the map will be displayed in the “Home”.

Note: The Ally™ Pro platform supports the following formats: png, jpg. PDF files cannot be used.



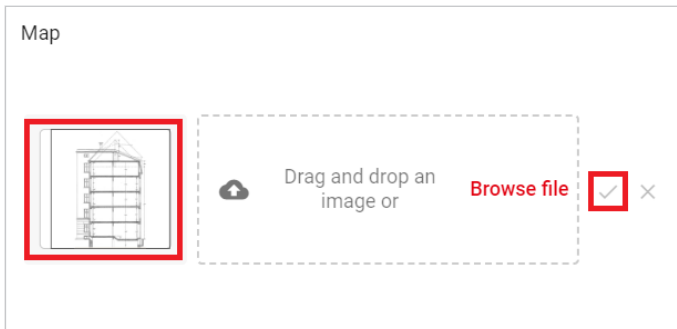
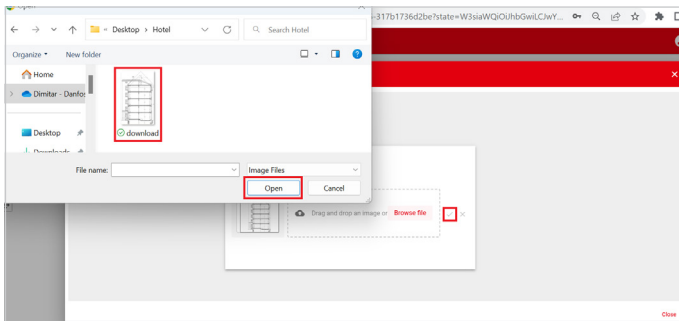

3. Screen “Home and zones” – After uploading the map, close the “Home Map” window. The map is now displayed on the “Home Map with Zones” screen.

Locations > Hotel Kolding > Homes and zones

Administration dashboard

Hotel Kolding

4.0 °C

Enabled

Home map with zones

Home alarms

🕒 Realtime - last 7 days

Created time	Device name	Alarm code	Message	Description
2023-10-01 03:34:11	Danfoss Ally® Room 1	Device status	Device is online.	✕
2023-10-01 03:34:09	Danfoss Ally® Room 5	Device status	Device is online.	✕
2023-10-01 03:34:09	Danfoss Ally® Room 1	Device status	Device is online.	✕
2023-10-01 03:34:09	Danfoss Ally® Room 2	Device status	Device is online.	✕
2023-10-01 03:34:08	Danfoss Ally® Room 3	Device status	Device is online.	✕
2023-10-01 03:34:08	Danfoss Ally® Room 4	Device status	Device is online.	✕
2023-10-01 03:34:08	Hotel Kolding	Device status	Device is online.	✕

Items per page: 10 | 1-7 of 7 | ⏪ ⏩

2.2.8. How to add a Zone

1. Screen “Home and zones” – Click on the “Add zone” icon.

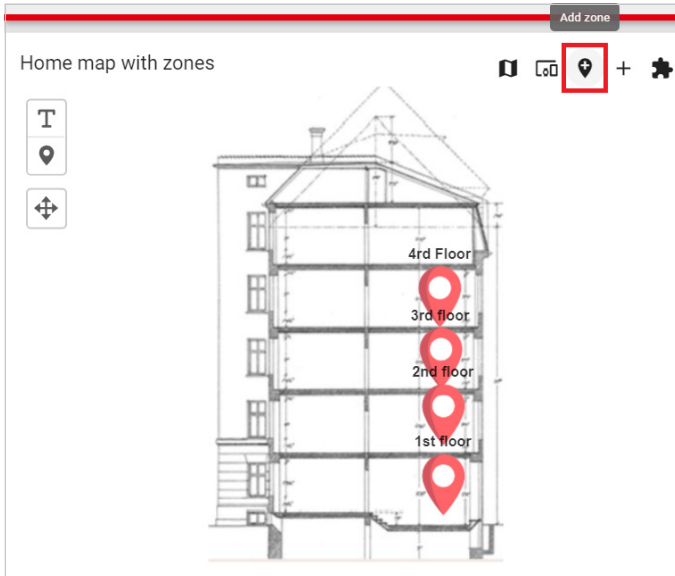

2. Pop-up window “Add zone” – After clicking on the “Add Zone”, a pop-up window will be displayed. In here, you should enter the zone name, then click “Create” button.

Note: Make sure to consider the naming of your devices thoroughly and use logical names. This will help you manage your location more effectively.

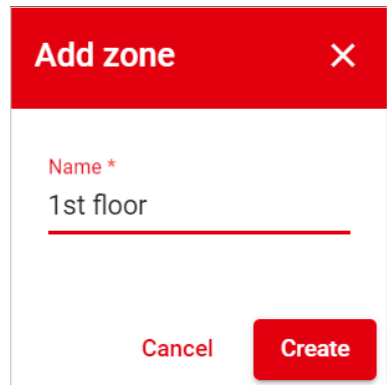

3. Screen “Home and zones” – After clicking on the “Create” button, the zone is created and you will be able to see it on the home map and in the “Zone management” list.

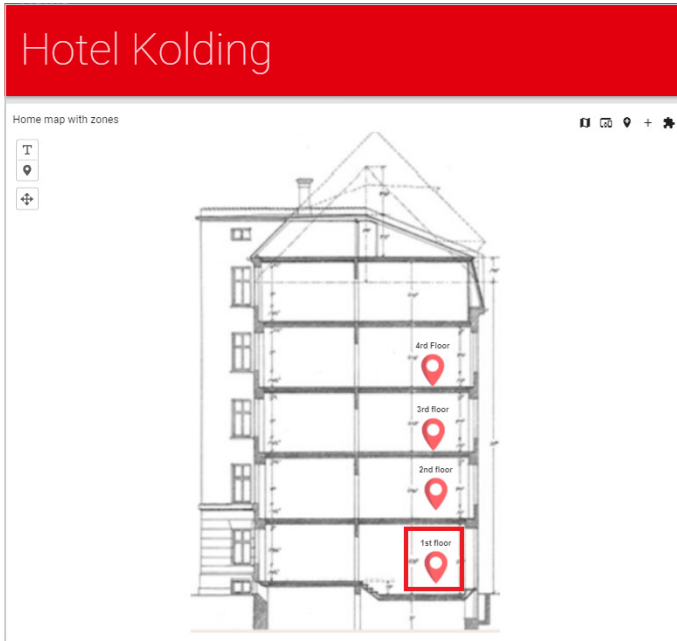

Zone management	
Name	
4rd Floor	
3rd floor	
2nd floor	
1st floor	

2.2.8.1. How to place Devices into the Zone

An already created zone is needed in order to be able to import devices.

1. Screen “Home and zones” – After creation of a zone, you can enter the zone by

1. Clicking directly on the zone pin icon on the “Home map with zone”;

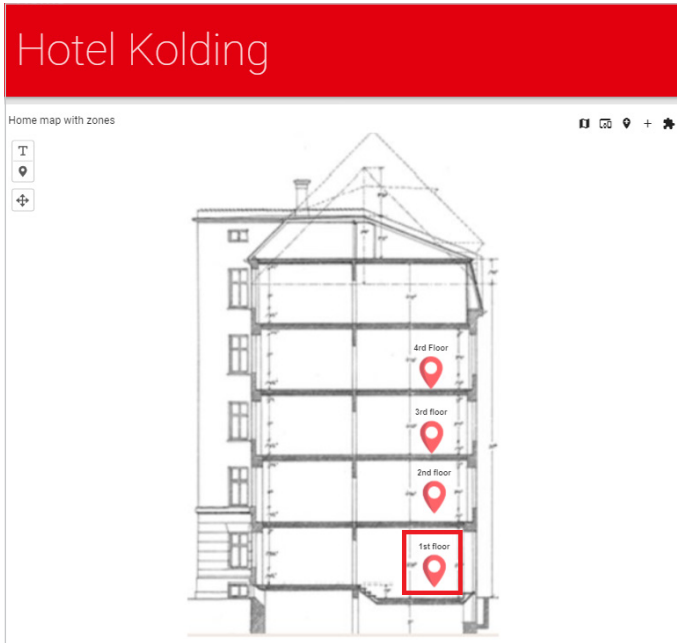

2. Clicking on the zone through the “Zone management” list.

Zone management	
Name	
4rd Floor	
3rd floor	
2nd floor	
1st floor	

2. Screen “Zone” – After clicking on the zone, you will be redirected to the “Zone (Zone LR)” page.

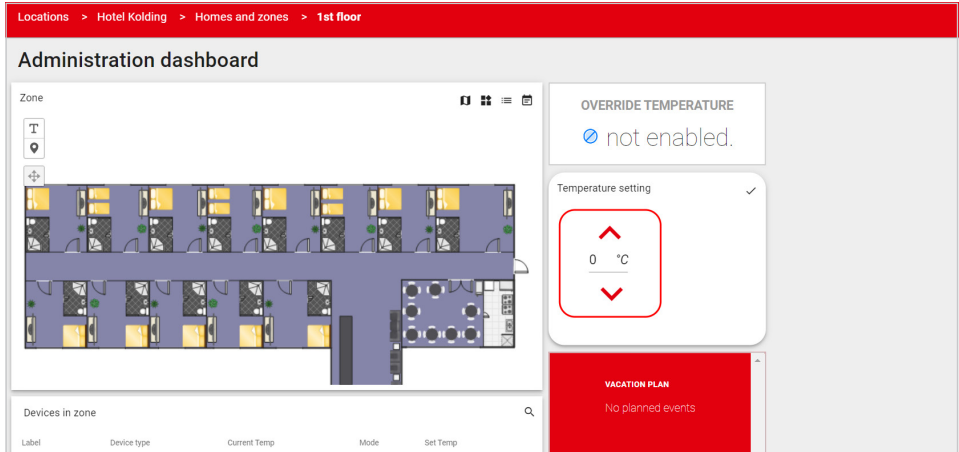

3. Screen “Zone” – Click on “Place devices in this zone”.



4. Pop-up window “Available devices” – After clicking on the “Place Devices in this Zone”, a pop-up window will be displayed in which you can see all available devices. Check the devices you wish to place in this zone, and click on the “Place into the zone” button.

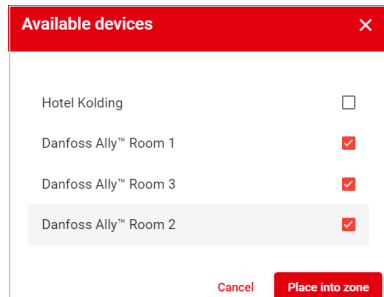

5. Screen “Zone” – After clicking on the “Place into zone” button, you will be able to see the devices in the “Zone” and also in the “Devices in zone” list.



2.2.8.2. How to remove Devices from a Zone

1. Screen “Zone” – The “Devices in Zone” list displays all devices you previously placed into the zone. Click on “Remove from zone (X)” icon if you wish to remove specific devices again.

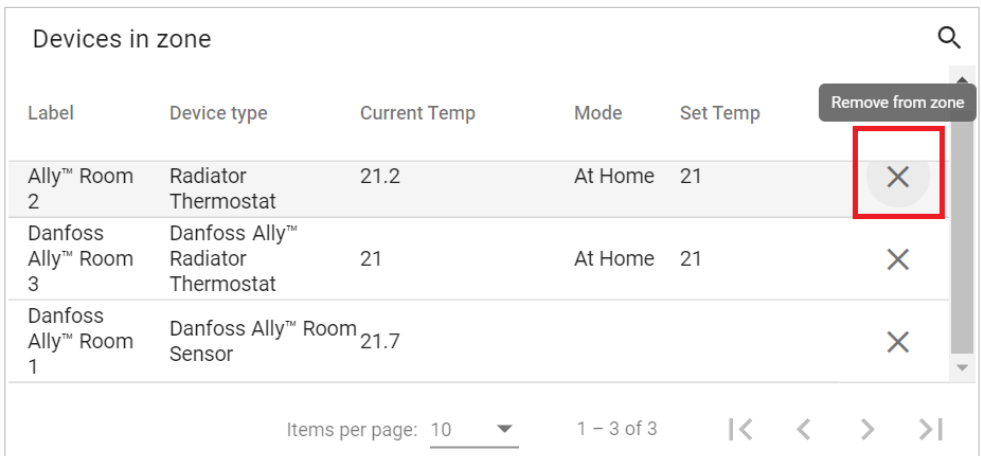

2. Pop-up window "Information" – After clicking on the "X" icon, the pop-up window "Information" will be displayed. You can now see that the device has been removed from the zone.

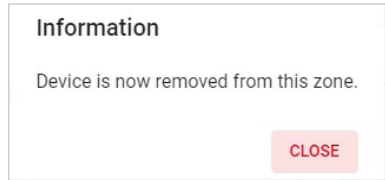

3. Screen "Zone" – In the "Zone" screen, the removed device is no longer visible.



2.2.8.3. How to change Zone Map

An already created zone is needed, in order to change the zone map.

1. Screen "Zone" – Click on the "Change zone map".

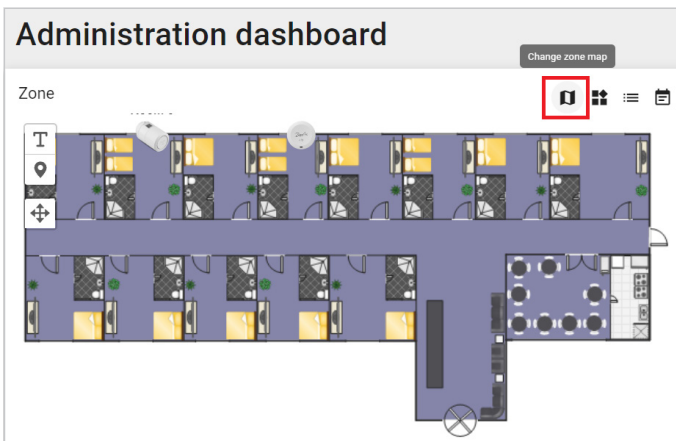

2. Pop-up window “Update area map” – After clicking on the **“Change zone map”** in the pop-up window, you can see instructions on how to upload the map. Click inside the map, and the file upload will open. Find the relevant map or image, and select the map or image.

You will be able to see the map or image on the map window. Click on the checkmark and the map or image will be displayed in the zone.

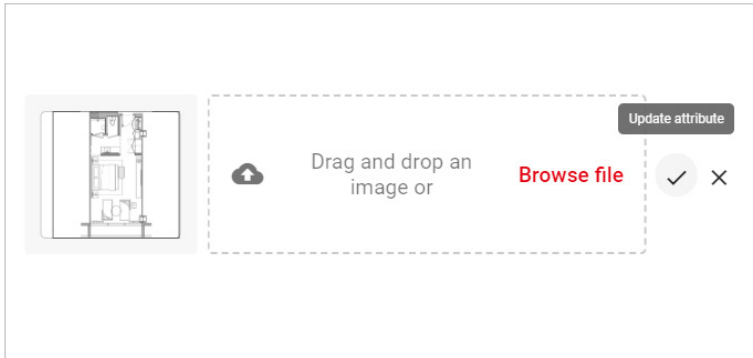

3. Screen “Zone” – After uploading the map, close the **“Update area map”** window the map is already displayed on the **“Zone”** screen.

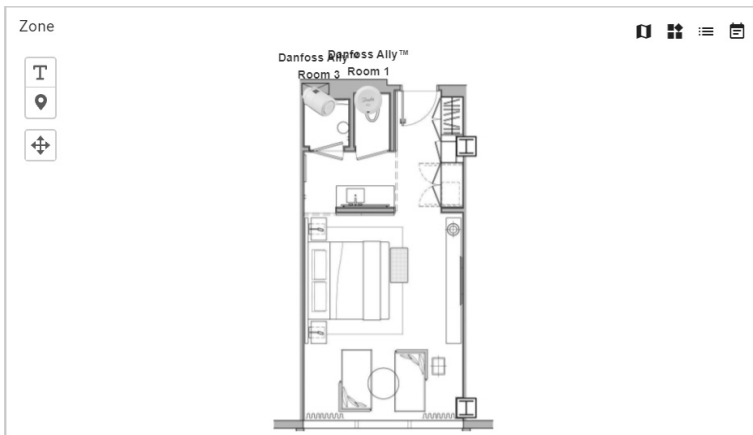

2.2.8.4. Add Vacation to the Zone

An already created zone is needed, in order to add a vacation to the zone.

1. Screen “Zone” – Click on the “Add vacation for this zone”.

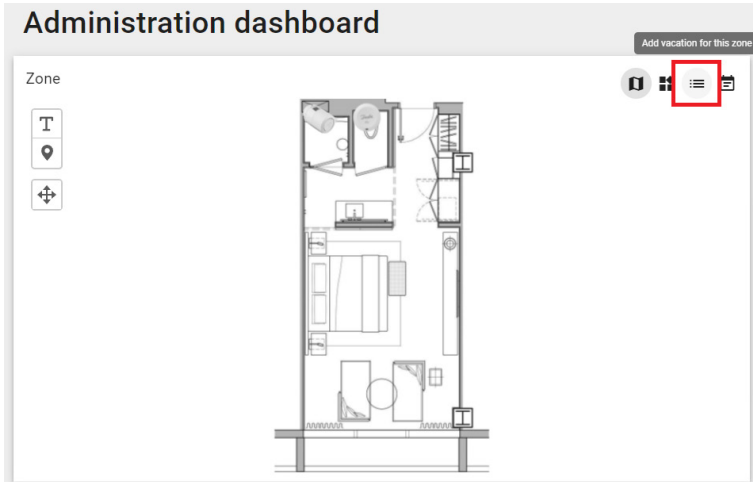

2. Pop-up window “Create vacation event:” – After clicking “Add Vacation for this Zone”, the following pop-up window is displayed: “Create vacation event”. In here, you can create your vacation period. After filling in the form, click “Create”.

The “Create vacation event” form contains:

- 1. Event type (dropdown menu);
- 2. Temperature (input field);
- 3. Timezone (dropdown menu);
- 4. Start time (date picker);
- 5. End time (date picker);
- 6. Create (button);
- 7. Cancel (button).



3. Screen "Zone" – After clicking the "Create" button, you will be back at the "Zone" screen and you can see the created vacation in the "Vacation plan" box.

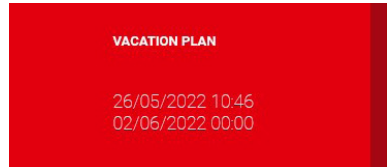

2.2.8.5. How to view Vacation Plan in the Calendar

An already created vacation event is needed in order to be able to see the vacation plan in the calendar.

1. Screen "Zone" – Click on the "Open calendar" button.

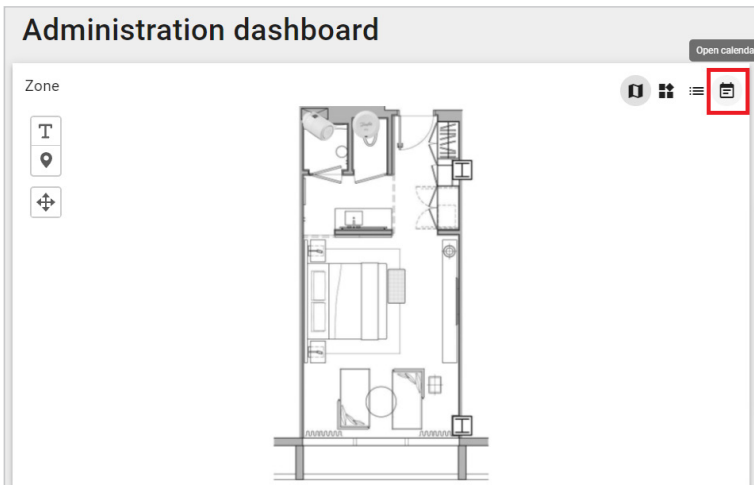

2. Screen "Calendar" – After clicking on the "Open calendar" button, you will be redirected to the "Calendar" page. You will be able to see the vacation plan marked with a yellow line from start date to end date in the calendar.

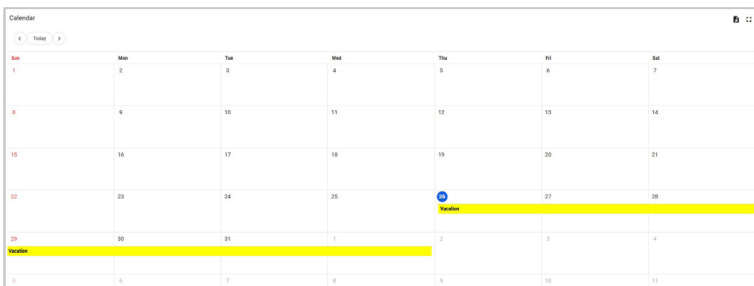

3. Screen “Calendar” – Click on the yellow line the pop-up window will be displayed and you will be able to see info for the vacation plan and delete the vacation plan.

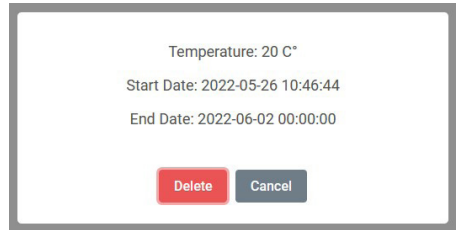

2.2.8.6. How to delete a Vacation Plan

1. Screen “Calendar” – Click on the yellow line, and the pop-up window will be displayed. Click on the “Delete” button.

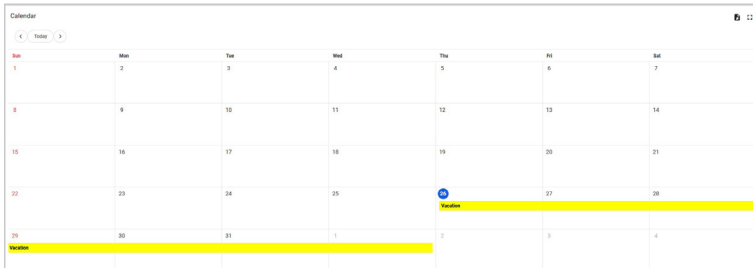

2. Screen “Confirmation message” – After clicking the “Delete” button, the window with the confirmation message will be displayed. The message will vary, depending on the fact whether the vacation has already started, or whether it will start in the future.

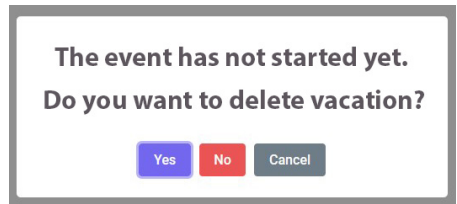
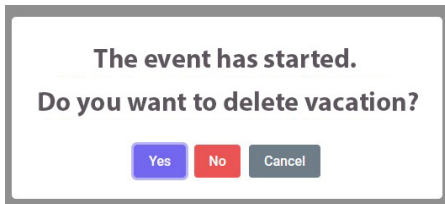

3. Screen “Confirmation message” – Click on the “Yes” button to delete the vacation and you will be redirected to the “Calendar” page. You can see that the vacation is deleted and the yellow line is removed from the calendar.

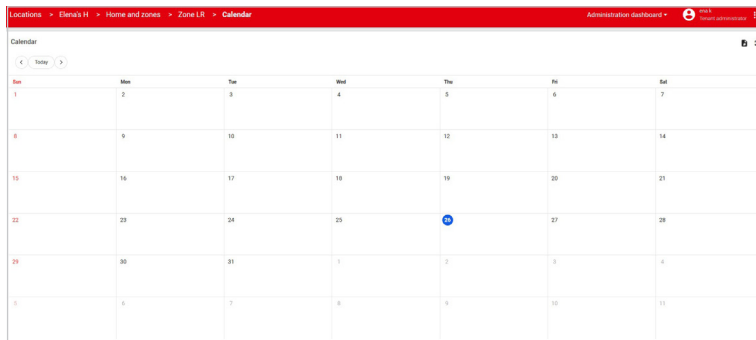

2.2.8.7. Temperature Setting in the Zone

1. Screen “Zone” – When a zone has been created, the temperature setting is 0 (C) as default, and the device set temperature is identical to any eventual already made settings.

If you wish to change the temperature in this given zone, you need to go to “temperature settings” and set the wanted temperature for the devices in the zone.

Zone

Devices in zone

Label	Device type	Current Temp	Mode	Set Temp
Danfoss Ally™ Room 3	Danfoss Ally™ Radiator Thermostat	19.8	Manual	19
Danfoss Ally™ Room 1	Danfoss Ally™ Room Sensor	20.1		

OVERVERRIDE TEMPERATURE
not enabled.

Temperature settings
0 °C

VACATION PLAN
No planned events

2. Screen “Zone” – First, you need to enter the wanted temperature in the “temperature settings” field. Press “enter” on your keyboard, and click on the checkmark icon to save the temperature. You will see that all device in the zone now have the entered temperature from “temperature settings” and the mode “manual”. Also, you can see that the entered temperature in the “temperature settings” field is displayed in the field “override temperature”.

Label	Device type	Current Temp	Mode	Set Temp
Danfoss Ally™ Room 3	Danfoss Ally™ Radiator Thermostat	20.5	Manual	18

2.2.8.8. How to change one specific Device Temperature in a Zone

1. Screen “Zone” – If you want to change the temperature on one specific device in a given zone, you need to click on that device.

Label	Type	Current Temp	Mode	Set Temp
EK eTRV	Danfoss Ally™ Radiator Thermostat	28.3	Manual	18
Elena eTRV	Danfoss Ally™ Radiator Thermostat	28.2	Manual	18

2. Screen “Device info page (name EK eTRV)” – When you click on it, you will be redirected to that device page and you will be able to see all details for it.

The screenshot displays the 'Device info page' for a Danfoss Ally™ Radiator Thermostat. The interface includes the following elements:

- Header:** 'Device type' and 'Danfoss Ally™ Radiator Thermostat'.
- Temperature Controls:** 'CURRENT TEMPERATURE' at 28.4 °C and 'SET TEMPERATURE' at 18 °C. Below the set temperature is an 'Update Temperature' section with up/down arrows and a numeric input field showing '18 °C'.
- Settings:** 'Child Lock' (Disabled) and 'Alarms' (Enabled).
- Battery:** A battery level indicator showing 68%.
- Data points:** A table listing various sensor data:

Window state	close
Work state	NoHeat
Upper Temperature	35.0 °C
Lower Temperature	5.0 °C
Mode	Manual
Child Lock	Disabled
Thermostat temperature	28.3 °C
- Mode:** A red bar at the bottom left indicates the device is in 'Manual' mode.
- Graph:** A 'Current Temperature' graph showing 'Realtime - last 7 days' with a red line and shaded area.

3. Screen “Device info page (name EK eTRV)” – You can change the temperature in the field “Update Temperature”. Enter the wanted temperature, and press “enter” on your keyboard, or press the “Go to manual mode” icon. You can see that the new temperature is displayed in the “Set temperature” field.

This screenshot shows the same device info page after the temperature has been updated. The 'Update Temperature' field now shows '19 °C', and the 'SET TEMPERATURE' field has updated to '19 °C'. The 'CURRENT TEMPERATURE' is now 28.5 °C. The 'Mode' bar remains in 'Manual' mode.

4. Screen “Zone” – Return to the zone and you will be able to see that the temperature for this device is changed. The “**temperature settings**” is in a default state of 0 C, and no “**override temperature**” is displayed.



Note: If temperature is changed for one specific device only, the other devices in the zone will keep the temperature from the “**temperature settings**” which were set up previously.

2.2.8.9. How to set a Schedule to a Zone

An already created zone is needed in order to set a schedule for the zone.

Note: In order to use the ‘Zone Schedule’ feature, it is necessary for the Radiator Thermostats to be in schedule mode. You can easily configure them to schedule mode directly from the Ally™ app.

1. Screen “Zone” – Click on the “**Create a schedule for the zone**” icon.

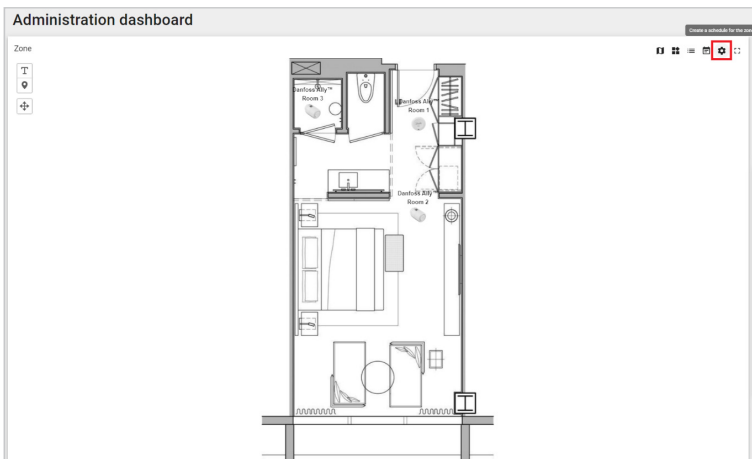

2. Screen “Zone Schedule” – After clicking on the “Create a schedule for the zone” you will be redirected to the “Zone Schedule” page.

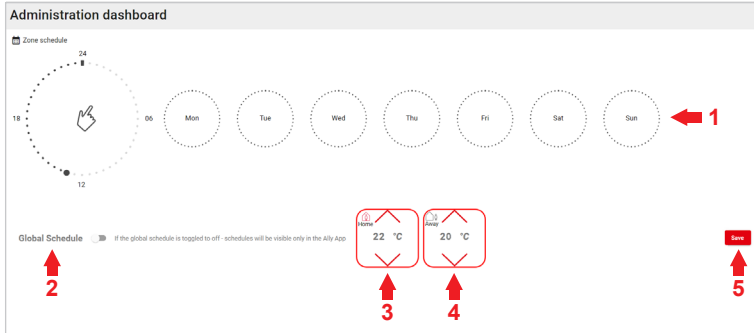

Zone Schedule contains:

- 1. Days of the week.
- 2. Global Schedule toggle.
- 3. At home temperature.
- 4. Away temperature.
- 5. Save button.

3. Screen “Zone Schedule” – Set “At home” and “Away” temperature.

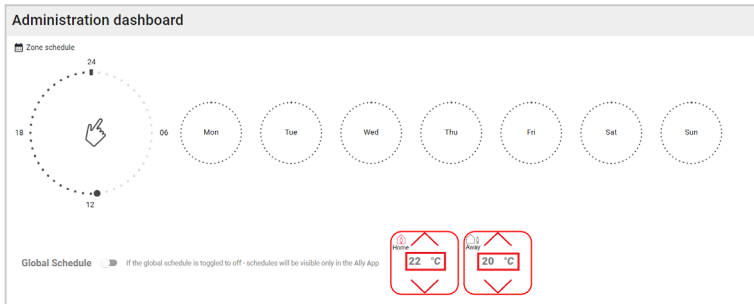

4. Screen “Zone Schedule” – Click on Mon or any other day.

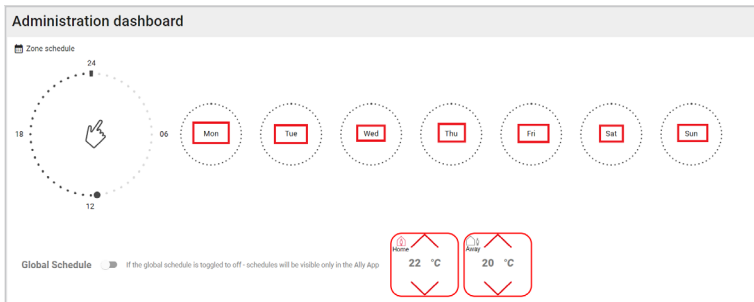

5. Screen “Monday Schedule” – After clicking on “Mon” a pop-up window will be displayed. Click on the “+” to add a “Period”.

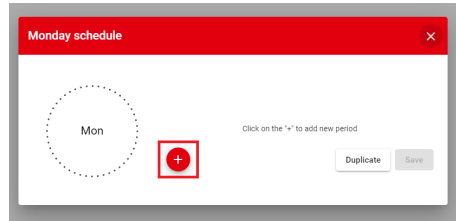

6. Screen “Monday Schedule” – After clicking on the “+” icon a “Period” will appear. Set it according to your preferences.

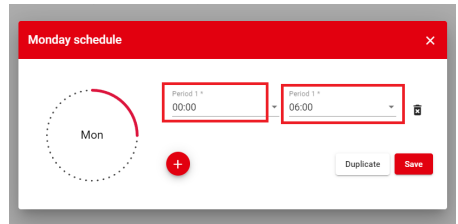

7. Screen “Monday Schedule” – Click on the “+” icon again. A new “Period” will appear. Set it according to your preferences and click on the “Save” button.

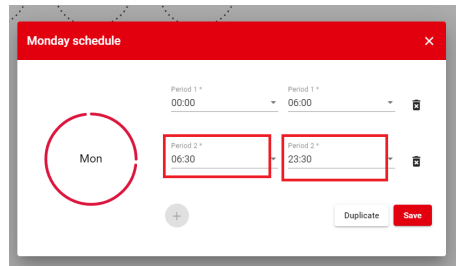

Note: You can create up to 3 “Periods”.

8. Screen “Zone Schedule” – The pop-up window will close. Click on the “Save” button to save the schedule.

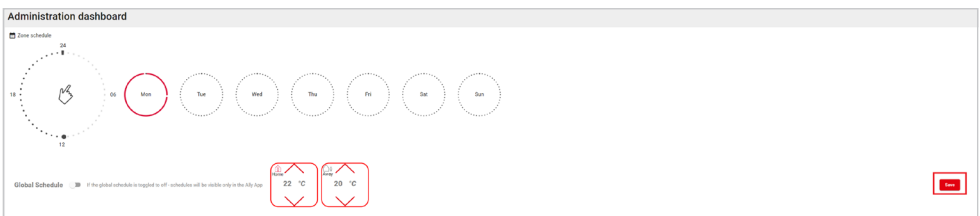

9. Screen “Zone Schedule” – Toggle “Global Schedule” to on. You will be able to see the schedule in Ally Pro.

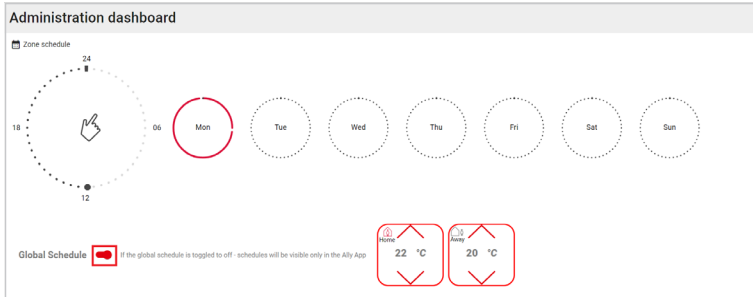

Note: If the “Global Schedule” is toggled to off – schedules will be visible only in the Ally app.

2.2.8.10. How to duplicate a Schedule

1. Screen “Zone Schedule” – Click the day that you want to duplicate.

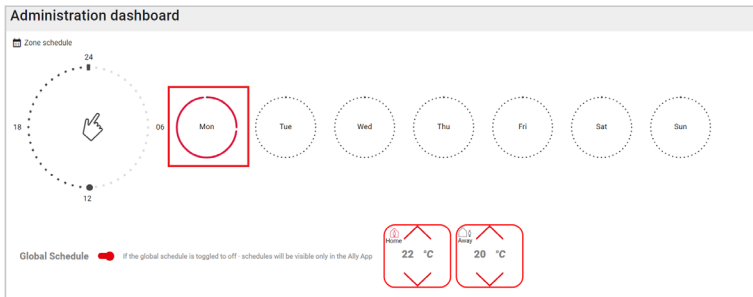

2. Screen “Monday Schedule” – A pop-up window will be displayed. Click on “Duplicate”.

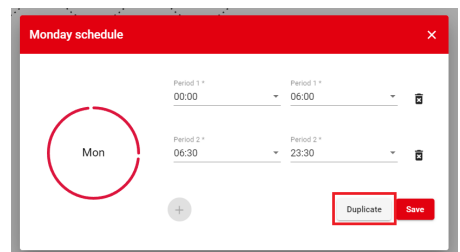

3. Screen “Duplicate Schedule” – A pop-up window will be displayed. Click on the days that you wish to set up. Click on the “Save” button.

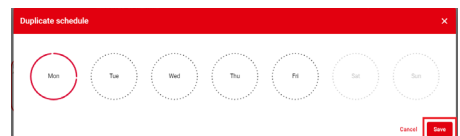

4. Screen “Zone Schedule” – The pop-up windows will close. Click on the **“Save”** button to save the schedule.

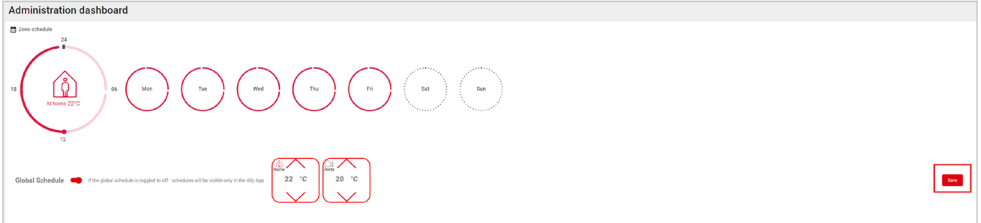

2.2.8.11. How to delete a Schedule

1. Screen “Zone Schedule” – Click on the schedule that you want to delete.

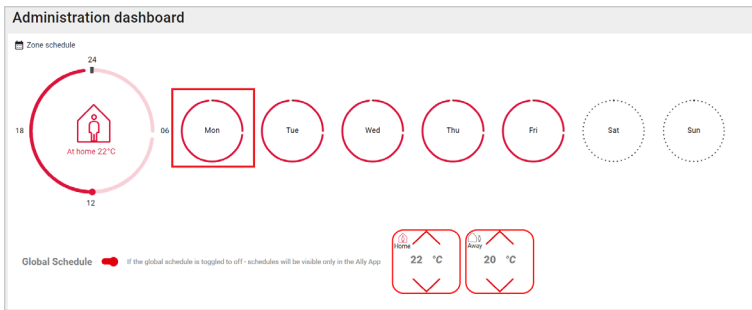

2. Pop-up window “Monday schedule” – After clicking on the schedule a pop-up window **“Monday schedule”** will be displayed. Click on the bin icon to remove the periods.

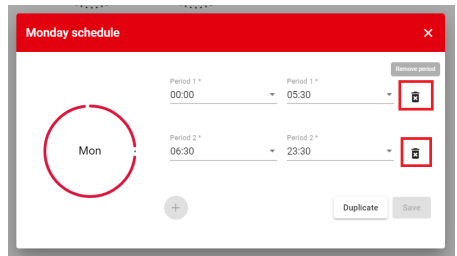

3. Pop-up window “Monday schedule” – After you remove the period click on the **“Save”** button.

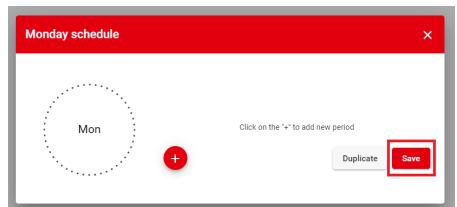

4. Screen “Zone Schedule” – After clicking on the “Save” button, the pop-up window will close. Click on the “Save” button to save the changes.

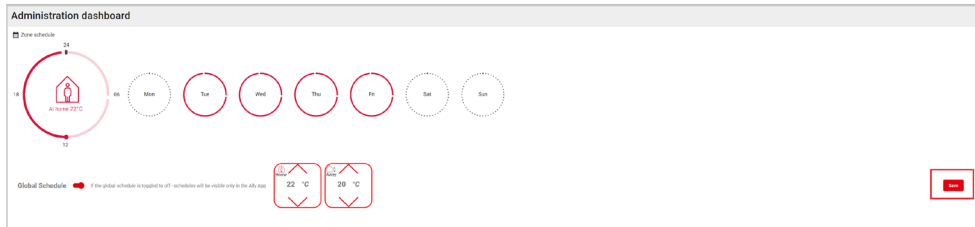

2.3. Device Alarms in Ally™ Pro

2.3.1. Enabled/disabled Alarms for all Devices

1. Screen “Home and zones” – the default status for the “Alarms” is always enabled when you first-time sign in.

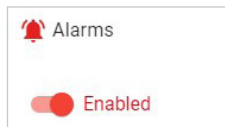

2. Screen “Home and zones” – When the widget “Alarms” is “enabled”, you can see the alarms for all devices in the “Home alarms” list.

Outdoor Temperature

27.4 °C

Alarms

Enabled

Home alarms 🔍 ☰

🕒 Realtime - last 7 days

Created time ↓	Device Name	Alarm code	Message	Description	
2022-06-02 13:57:43	Elena eTRV	E6	Motor jammed, try re-start, try reboot, try re-mount, if the error persists the device faulty, Code E6	Motor error	✕
2022-06-02 13:57:13	Home Sensor	E2	Device faulty, Code E2	Side PCB sensor error	✕
2022-06-02 13:55:30	EK eTRV	E2	Device faulty, Code E2	Side PCB sensor error	✕

Items per page: 10 1 – 3 of 3 < >

3. Screen “Home and zones” – When the widget “Alarms” is toggled to “disabled”, the alarms for all devices disappear in the “Home alarms” list.

2.3.2. Enabled/disabled Alarms per Device

An already opened device is needed, in order to enable/disable alarms.

1. Screen “Device (EK eTRV name of the device)” – If the “Alarms” widget is “enabled”, you can see all alarms for this device in the “Home alarms” list.

Home alarms 🔍 ☰

🕒 Realtime - last 7 days

Created time ↓	Device Name	Alarm code	Message	Description	
2022-06-02 13:57:43	Elena eTRV	E6	Motor jammed, try re-start, try reboot, try re-mount, if the error persists the device faulty, Code E6	Motor error	✕
2022-06-02 13:57:13	Home Sensor	E2	Device faulty, Code E2	Side PCB sensor error	✕
2022-06-02 13:55:30	EK eTRV	E2	Device faulty, Code E2	Side PCB sensor error	✕

Danfoss eTRV E-error codes description: <https://assets.danfoss.com/documents/199103/AM398144307765en-000104.pdf>

2. Screen “Device (EK eTRV name of the device)” – If the “Alarms” widget is “Disabled”. The alarms for this device won’t be shown in the “Home alarms” list.

Device type

Danfoss Ally™ Radiator Thermostat

CURRENT TEMPERATURE

🌡️ 28.9 °C

SET TEMPERATURE

🌡️ 17 °C

🔒 Child Lock

Disabled

🔔 Alarms

Disabled

🔄 Update Temperature

⬆️

15 °C

⬆️

Mode

Away

Home alarms 🔍 🗖

🕒 Realtime - last 7 days

Created time ↓	Device Name	Alarm code	Message	Description	
2022-06-02 13:57:43	Elena eTRV	E6	Motor jammed, try re-start, try reboot, try re-mount, if the error persists the device faulty, Code E6	Motor error	✕
2022-06-02 13:57:13	Home Sensor	E2	Device faulty, Code E2	Side PCB sensor error	✕

2.3.3. Home Alarms List

1. Screen "Home and zones" – You have the option for the alarms how days you can see all the alarms in the "Home alarms" list. Click on the "Edit time-window" icon, the menu will be displayed with the dropdown option "Last" to choose how many days you want to see alarms and "Interval (your time-zone)" in the "Home alarms" list.

Home alarms 🔍 🗖

🕒 Realtime - last 7 days

Realtime History

Last

Last Advanced

7 days 🔍

Interval

Timezone

Browser Time (UTC+02:00) ✕

Cancel Update

Created time ↓	Device Name	Alarm code	Message	Description	
2022-06-02 13:57:43	Elena eTRV	E6	Motor jammed, try re-start, try reboot, try re-mount, if the error persists the device faulty, Code E6	Motor error	✕
2022-06-02 13:57:13	Home Sensor	E2	Device faulty, Code E2	Side PCB sensor error	✕

2. Screen “Home and zones” – Click on the tab “History”, and a menu with three options (Last – dropdown menu with time; Time Period – radio button; Interval – timezone) is displayed.

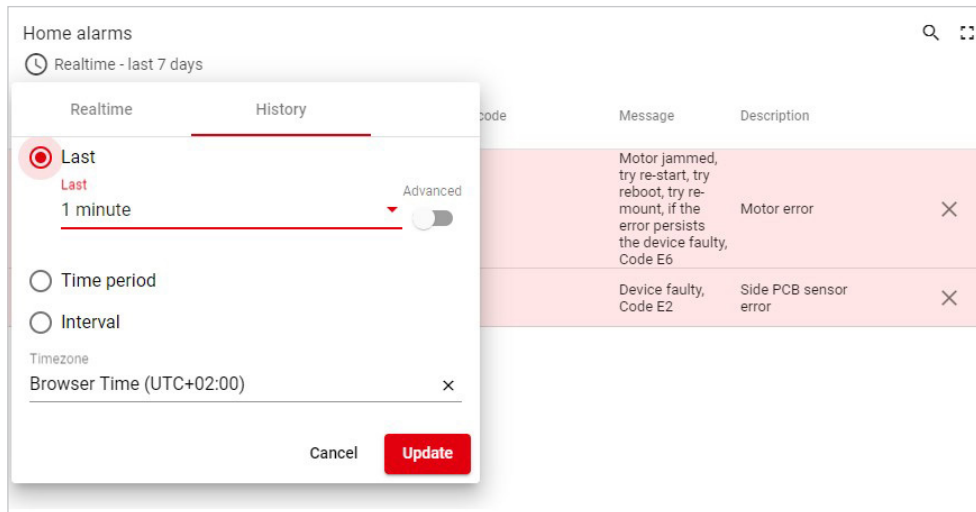

3. Screen “Home and zones” – Also, you have another two options in the “Home alarms” list the options “Search” and “Expand to fullscreen”.

1. Option “Search” – When you click on the “Search” icon the search bar will be displayed, you need to search alarms according to the “Alarm code”.

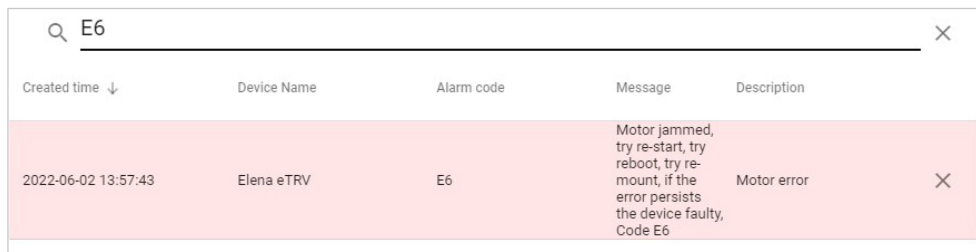

2. Option “Expand to fullscreen” where you have the option to see the alarms in fullscreen.

2.4. ECL in Ally™ Pro

Electronic controllers (ECL) are intelligent temperature regulators for district heating and domestic hot water systems. By means of weather compensation and application keys, they can be adapted to a variety of district heating systems, ensuring a high level of comfort and optimum energy utilization.

2.4.1. How to add ECL Device

An already imported home is needed in order to be able to add the ECL device to the home.

1. Screen “Home and zones” – You need to click on the “+” icon to add an ECL device to the home.

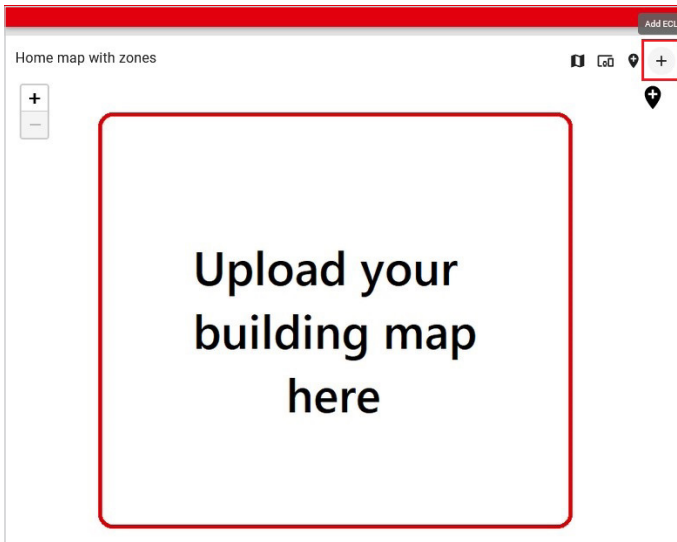

2. Pop-up window “Add ECL” – After clicking on the “Add ECL” + icon the pop-up window “Add ECL” will be displayed. You need to fill in the form and click on the “Add ECL device” button.

Add ECL-form contains:

1. ECL access code (input field);
2. Serial number (input field);
3. Cancel (button);
4. Add ECL device (button).

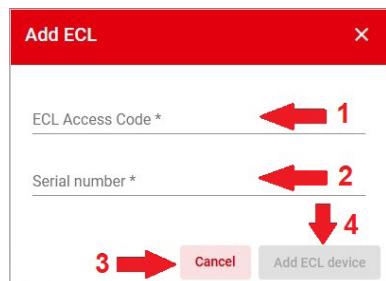

3. Screen “Home and zones” – After clicking on the “Add ECL device” button, you will be able to see the ECL device in the “All devices in home” list.

All devices in home								
Device Name	Type	Current Temp	Set Temp	Manual Temp	Child Lock	Online	Battery	Outdoor Temperature
Ally™ Pro test , Ally™ Pro test street 17	ECL Subdevice					Online		-0.4

Items per page: 10 1 - 1 of 1

2.4.2. How to create an ECL Home without an Ally™ Account

An already created location is needed, in order to proceed with creating an ECL Home.

1. Screen “Location (the name of your location)” – Go to “Accounts” and click on the “Add new account” + icon.

Locations > Location

Home
🗑️ 🔍 🔄

No data to display on widget

Add new account

Accounts
+ 🔍

Home ↑
Email
Ally™ Email

No entities found

Items per page: 10 0 of 0
⏪ ⏩

2. Pop-up window “Add new account” –

After clicking on the “Add new account” icon, you need to enter a valid email. You can also proceed with the email already used for the ECL portal. Then, click the “Create” button.

3. Screen “Location (the name of your location)” – After you fill out the form “Add new account” and click on the “Create” button, you will be able to see the created account in the “Accounts” box. Click on the “Create ECL home without Ally™ account”  icon.

4. Pop-up window “Add home” – After clicking on the “Create ECL home without Ally™ account” a pop-up window will be displayed. Fill out the “Add Home” form and click on the “Create” button. You can see the home that you have created in the “Home” box. Click on it to open.

5. Screen “Home and zones” – Click on the “Add ECL” **+** icon.

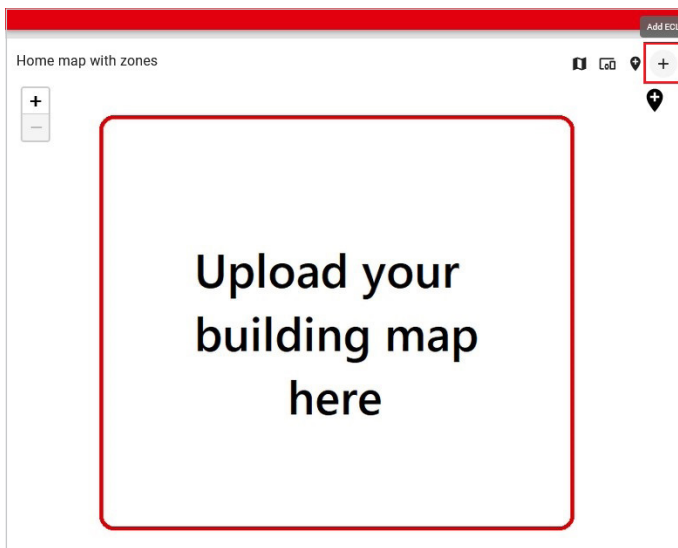

6. Pop-up window “Add ECL” – After clicking on the “Add ECL” **+** icon, the pop-up window “Add ECL” will be displayed. You need to fill in the form and click on “Add ECL device”.

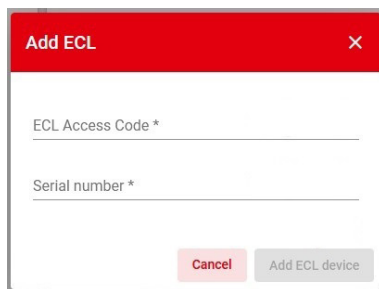

7. Screen “Home and zones” – After clicking on the “Add ECL device” button you will be able to see the ECL device in the “All devices in home” list.

All devices in home									
Device Name	Type	Current Temp	Set Temp	Manual Temp	Child Lock	Online	Battery	Outdoor Temperature	
Ally™ Pro test, Ally™ Pro test street 1?	ECL Subdevice					Online		-0.4	

Items per page: 10 1 - 1 of 1 |< < > >|

2.4.3. ECL Devices

An already imported ECL device is needed, in order to be able to open it.

1. Screen “ECL device” – After you open the “ECL device” you will be redirected to the ECL device page.

The screenshot displays a schematic diagram of an ECL system with three parallel circuits. Each circuit includes a radiator, a pump (P1, P2, P3), and a valve (M1, M2, M3). Temperature sensors (S1-S9) are placed at various points in the system. On the right side, a data table provides details for the device.

59991	
Owner name	Ally™ Pro test
Location street	Ally™ Pro test street
Location street number	17
Location ZIP	8260
Location city	Viby J
Location country	Denmark
App	A390.1
App Version	3.00
Software	2.00
Software Build No	9975
Hardware	ECL 310, 230 V
Production week	8.2013

2. Screen “ECL device” – You can see the diagram for the imported ECL, with the menus for setting up the ECL. On the right side, all data on the ECL is available.

This screenshot shows a simplified schematic of the ECL system with a temperature of 1.3 °C. A data table on the right provides the same information as the previous screenshot.

Owner name	Ally™ Pro test
Location street	Ally™ Pro test street
Location street number	17
Location ZIP	8260
Location city	Viby J
Location country	Denmark
App	A390.1
App Version	3.00
Software	2.00
Software Build No	9975
Hardware	ECL 310, 230 V
Production week	8.2013

3. Screen “ECL device” – You have six options/ menus for set-up.

1. Heating Circuit Menu where you can select the circuit and set the “**Comfort Room Setpoint**” and “**Saving Room Setpoint**” temperatures.

Note: When you enter a temperature in the “**Comfort Room Setpoint**” or “**Saving Room Setpoint**” fields, you need to click on the “**Comfort Room**” or “**Saving Room**”, so that the entered temperature is saved.

2. ECL MVP Menu where you can select the circuit and choose the “**Mode operation**” for the ECL device.

Note: The circuit and mode menus have dropdown menus in which you can select which mode to work with. Status is automatically set, depending on the chosen mode from the dropdown menu.

3. Flow Temperature Curve where you can set the flow temperature for the circuit.

The screenshot shows the 'Heating Circuit Menu' interface. At the top, there is a red header with the title 'Heating Circuit Menu' and a close button 'X'. Below the header, there is a dropdown menu for 'Circuit *' with the value '1'. Underneath, there is a field for 'Comfort Room Setpoint *' with the value '20' and a small up/down arrow icon. Below this is a red button labeled 'Comfort Room'. Then, there is a field for 'Saving Room Setpoint *' with the value '16' and a small up/down arrow icon. Below this is a red button labeled 'Saving Room'. At the bottom right, there is a 'Cancel' button.

The screenshot shows the 'ECL Menu' interface. At the top, there is a red header with the title 'ECL Menu' and a close button 'X'. Below the header, there are two dropdown menus: 'Circuit *' with the value '1' and 'Mode *' with the value 'Scheduled operation'. Below these is a field for 'Status' with the value 'Setback'. At the bottom right, there are two buttons: 'Cancel' and 'Save'.

The screenshot shows the 'Flow Temperature Curve' interface. At the top, there is a red header with the title 'Flow Temperature Curve' and a close button 'X'. Below the header, there is a dropdown menu for 'Circuit *' with the value '1'. The main area contains a grid of temperature settings, each with a 'Save' button:

Max. Flow Temperature 90	Save	Min. Flow Temperature 10	Save
Flow temperature at -30°C 75	Save	Flow temperature at -15°C 60	Save
Flow temperature at -5°C 50	Save	Flow temperature at 0°C 45	Save
Flow temperature at 5°C 40	Save	Flow temperature at 15°C 28	Save

At the bottom right, there is a 'Cancel' button.

4. Domestic Hot Water (DHW) Circuit Menu where you can select the circuit and set the “Comfort DHW Setpoint” and “Saving DHW Setpoint” temperatures.

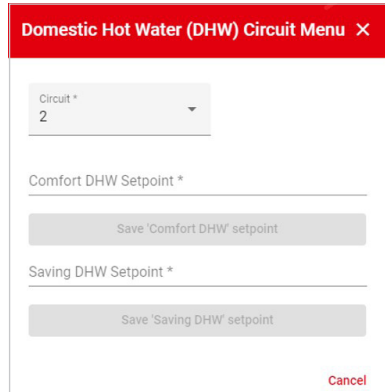

Note: When you enter a temperature in the “Comfort DHW Setpoint” or “Saving DHW Setpoint” fields, you need to click on “Save ‘Comfort DHW’ setpoint” or “Save ‘Saving DHW’” fields, so that the entered temperature is saved.

5. Export widget data where you can have three options to export the data.

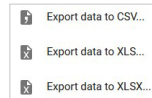

6. Expand to fullscreen to see the diagram in fullscreen.

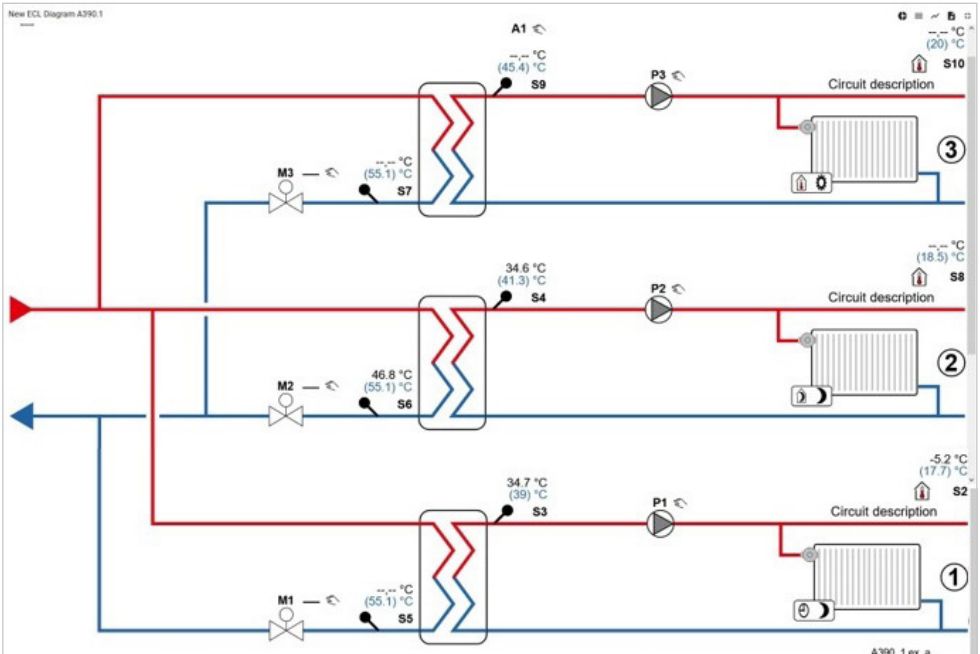

4. Screen “ECL device” – You have two options, as shown in the information box in the right corner.

1. Export widget data where you can have three options to export the data.

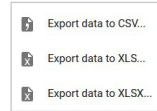

2. Expand to fullscreen to see the diagram in fullscreen.

59991	
Owner name	Ally™ Pro test
Location street	Ally™ Pro test street
Location street number	17
Location ZIP	8260
Location city	Viby J
Location country	Denmark
App	A390.1
App Version	3.00
Software	2.00
Software Build No	9975
Hardware	ECL 310, 230 V
Production week	8.2013

2.4.4. How to link Devices with ECL

An already imported ECL device is needed, in order to be able to link devices.

1. Screen “Home and zones” – You need to click on the “Link devices with ECL” icon.

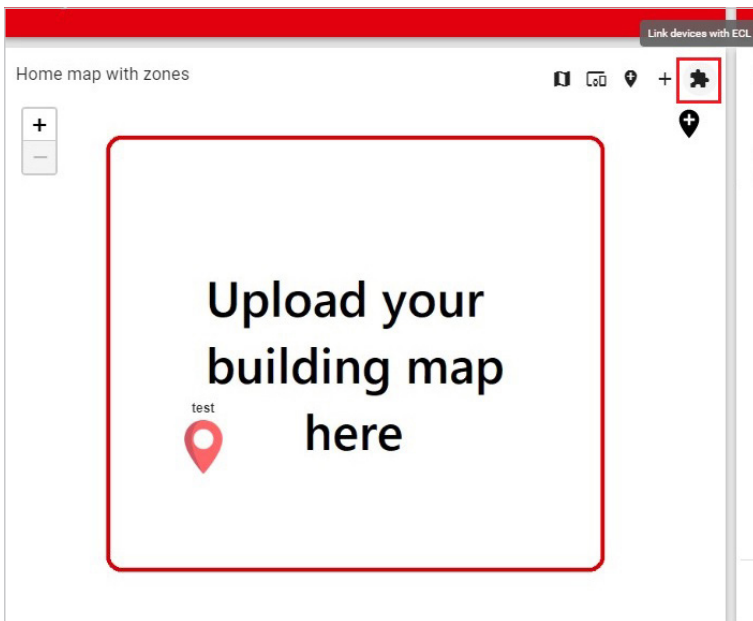

2. Pop-up window “Link devices with ECL” – After clicking on the “Link devices with ECL” icon, the pop-up window “Link devices with ECL” will be displayed. Here, you can see all thermostats, and in the dropdown menu, the ECL devices which are imported into your home.

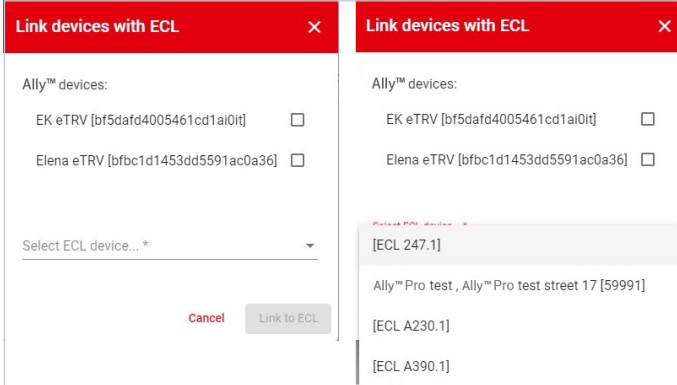

3. Pop-up window “Link devices with ECL” – Select from the dropdown menu an ECL device, then checkmark the device/s you want to link and click on the “Link to ECL” button.

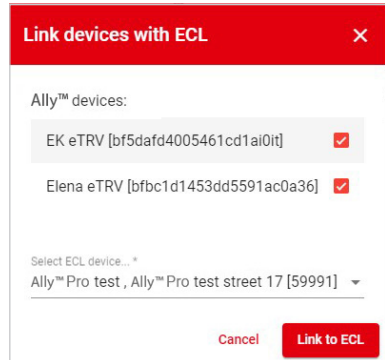

Note: If a specific thermostat is linked with one ECL device, you will not be able link it to another ECL (In the pop-up window “Link devices with ECL”, this specific thermostat is disabled and cannot be selected.)

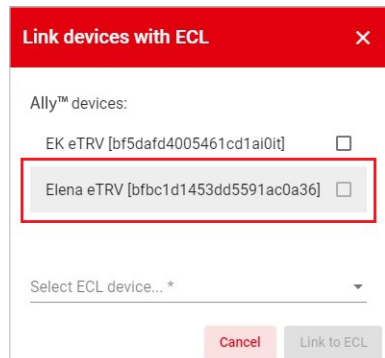

4. Screen "Home and zones" – After clicking on the "Link to ECL" button, you are back on the "Home and Zones" screen. Go to "All devices in Home" and click on the ECL which you previously linked to the thermostats. By clicking on the ECL device, you will be redirected to the screen of this specific ECL.

Device Name	Type	Current Temp	Set Temp	Manual Temp	Child Lock	Online	Battery	Outdoor Temperature
Ally™ Pro test, Ally™ Pro test street 17	ECL Subdevice					Online		0.1
EK eTRV	Danfoss Ally™ Radiator Thermostat	28.9 °C	18 °C	17 °C	Disabled	Online	65 %	
Gateway E1	Danfoss Ally™ Gateway					Online		
Elena eTRV	Danfoss Ally™ Radiator Thermostat	28.7 °C	18 °C	10 °C	Disabled	Online	80 %	
Sensor elena home	Danfoss Ally™ Room	29.1 °C				Online	99 %	

5. Screen "ECL device" – After being redirected to the ECL display under the diagram, the "Linked Ally™ devices" list will display the thermostats linked to this ECL device.

Name	Type	Device Id	PI Heating Demand
EK eTRV	Danfoss Ally™ Radiator Thermostat	bf5dafd4005461cd1ai0it	0
Elena eTRV	Danfoss Ally™ Radiator Thermostat	bfbc1d1453dd5591ac0a36	0

6. Screen "ECL device" – If you want to remove a single thermostat link, you can click on the "✕" icon. If you want to remove all thermostat links from the ECL, you can do so by clicking on the "✕" icon. All thermostats will be removed from this ECL.

Name	Type	Device Id	PI Heating Demand
EK eTRV	Danfoss Ally™ Radiator Thermostat	bf5dafd4005461cd1ai0it	0
Elena eTRV	Danfoss Ally™ Radiator Thermostat	bfbc1d1453dd5591ac0a36	0

↓

Name	Type	Device Id	PI Heating Demand
Elena eTRV	Danfoss Ally™ Radiator Thermostat	bfbc1d1453dd5591ac0a36	0

Linked Ally™ devices					
Name	Type	Device Id	Pi Heating Demand		
EK eTRV	Danfoss Ally™ Radiator Thermostat	bf5dafd4005461cd1a10it	0		
Elena eTRV	Danfoss Ally™ Radiator Thermostat	bfbc1d1453dd5591ac0a36	0		
Linked Ally™ devices					
Name ↑	Type	Device Id	Pi Heating Demand		
No entities found					



Danfoss A/S

Climate Solutions • danfoss.com • +45 7488 2222

Any information, including, but not limited to information on selection of product, its application or use, product design, weight, dimensions, capacity or any other technical data in product manuals, catalogues descriptions, advertisements, etc. and whether made available in writing, orally, electronically, online or via download, shall be considered informative, and is only binding if and to the extent, explicit reference is made in a quotation or order confirmation. Danfoss cannot accept any responsibility for possible errors in catalogues, brochures, videos and other material. Danfoss reserves the right to alter its products without notice. This also applies to products ordered but not delivered provided that such alterations can be made without changes to form, fit or function of the product.

All trademarks in this material are property of Danfoss A/S or Danfoss group companies. Danfoss and the Danfoss logo are trademarks of Danfoss A/S. All rights reserved.